

UP-RW0645

For standby power supplies

Expected trickle life:3~5 years at 25°C, approx.5 years at 20°C



Contents indicated (including the recycle marking, etc) are subject to change without notice.

Dimensions(mm)

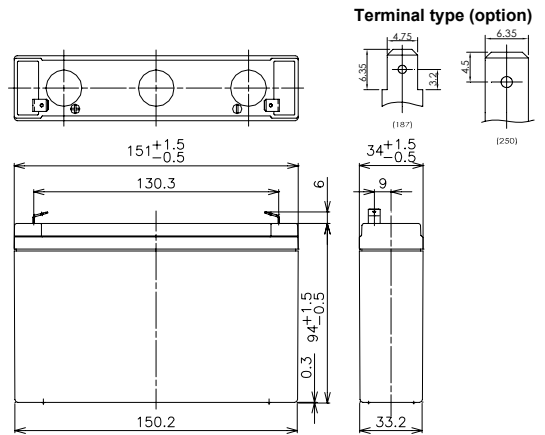

Battery case resin:standard(UL94HB)

Specification

Nominal Voltage		6V
Nominal Capacity		45W/cell@10MR
Dimensions	Length	151 mm
	Width	34 mm
	Height	94 mm
	Total height	100 mm
Approx. Mass		1.3 kg
Terminal		Faston 187 & 250

Characteristics

Capacity (25 °C)	30 minute rate	56W
	15 minute rate	97W
	10 minute rate	134W
	5 minute rate	205W
Internal Resistance	Fully charged battery (25 °C)	10 mΩ
Temperature Dependency of Capacity (20 hour rate)	40 °C	102%
	25 °C	100%
	0 °C	85%
	-15 °C	65%
Self Discharge (25 °C)	After 3 months	91%
	After 6 months	82%
	After 12 months	64%

Duration of discharge vs. discharge current

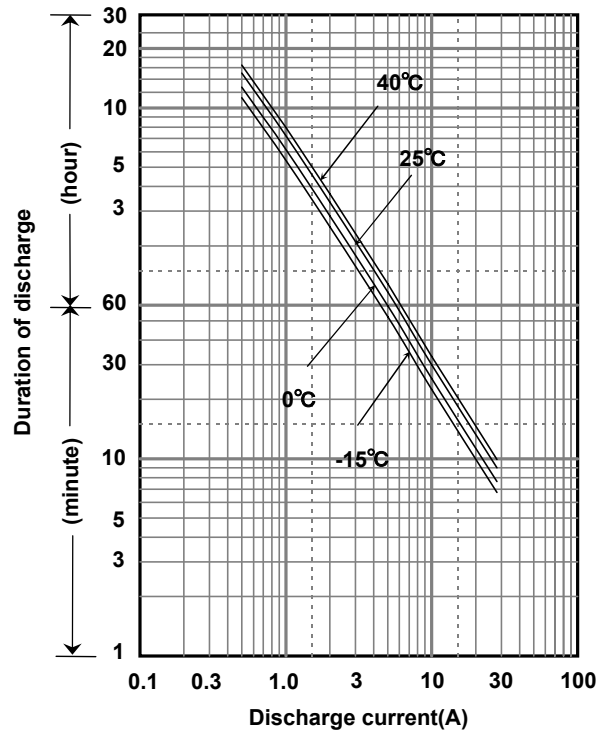

Watt Table(25°C)

Cut-off V	3min	5min	10min	15min	20min	30min	45min	1h	1.5h	2h	3h	4h	5h	6h	10h	20h	24h
4.8V	265	205	134	97.5	79.5	56.0	41.1	32.8	22.6	17.5	13.0	10.0	8.25	6.63	4.39	2.38	1.99
4.95V	254	200	131	97.2	78.9	55.9	40.8	32.8	22.1	17.3	12.9	9.92	8.18	6.60	4.37	2.37	1.98
5.1V	245	195	129	96.5	78.0	55.5	40.4	32.2	21.7	16.9	12.8	9.86	8.12	6.55	4.33	2.37	1.97
5.25V	231	180	123	93.4	75.4	55.0	39.3	31.5	20.8	16.4	12.8	9.85	8.07	6.48	4.31	2.36	1.97
5.4V	217	165	117	90.0	73.0	54.5	39.1	30.9	20.6	15.5	12.4	9.66	7.85	6.37	4.26	2.35	1.95

Ampere Table(25°C)

Cut-off V	3min	5min	10min	15min	20min	30min	45min	1h	1.5h	2h	3h	4h	5h	6h	10h	20h	24h
4.8V	47.7	36.8	23.9	17.0	13.7	9.57	6.99	5.57	3.82	2.95	2.19	1.67	1.38	1.11	0.732	0.397	0.331
4.95V	45.8	35.9	23.5	16.9	13.6	9.55	6.95	5.57	3.75	2.93	2.17	1.66	1.37	1.10	0.729	0.396	0.330
5.1V	44.1	35.0	23.0	16.8	13.5	9.49	6.88	5.46	3.67	2.86	2.15	1.65	1.36	1.09	0.721	0.394	0.329
5.25V	41.6	32.3	22.0	16.3	13.0	9.40	6.70	5.35	3.53	2.77	2.16	1.65	1.35	1.08	0.718	0.393	0.328
5.4V	39.0	29.6	20.9	15.7	12.6	9.32	6.67	5.25	3.50	2.62	2.08	1.62	1.31	1.06	0.710	0.391	0.326

■ Charging Method

(25°C)

Trickle use	Control voltage 6.8-6.9V; Initial current 1.2A or smaller
-------------	---

■ Cut off voltage

Discharge current	0.4A-1.6A	1.6A-4A	4A-8A	8A-16A	16A-24A
Cut off voltage (V)	5.25	5.1	4.95	4.65	4.35

■ Influence of Temperature on Trickle life

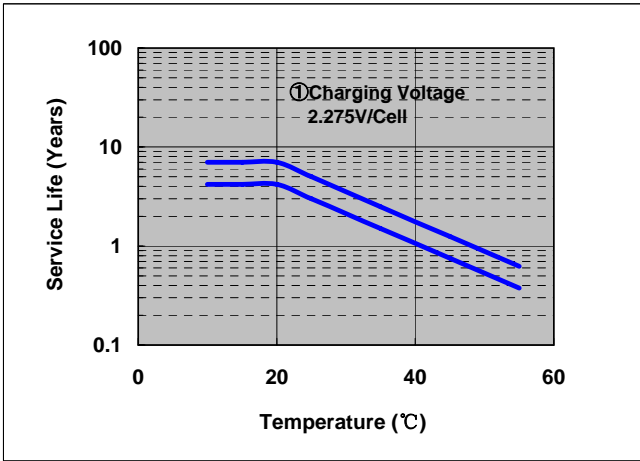

■ Residual capacity test result

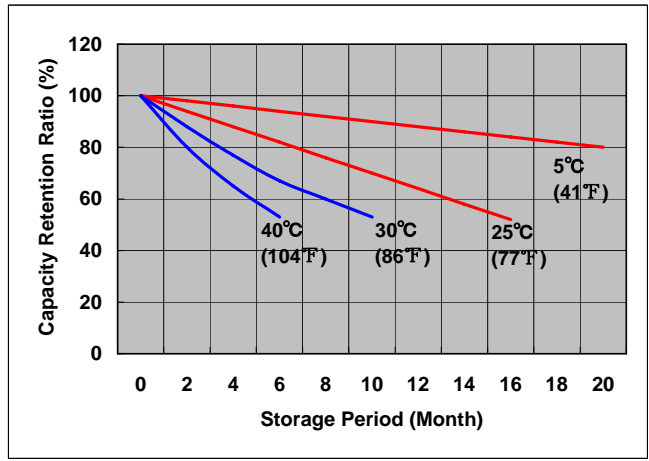

■ Constant-voltage and constant-current charge characteristics

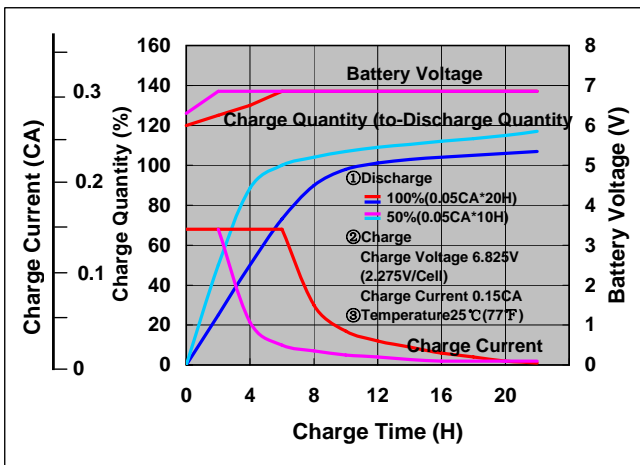

■ Discharge capacity by temperature and by discharge current

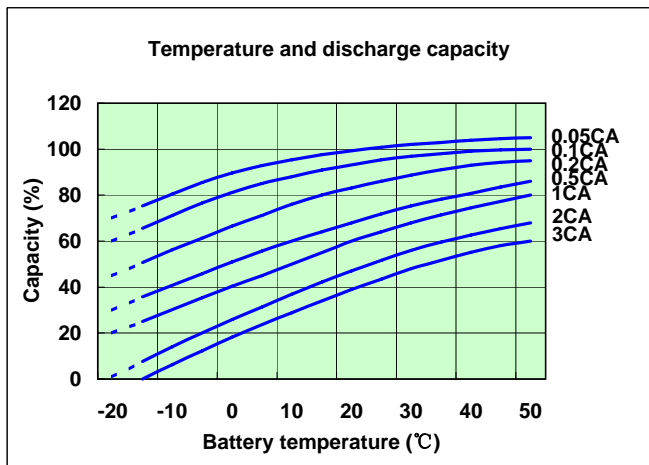

■ Discharge characteristics (25°C)

