

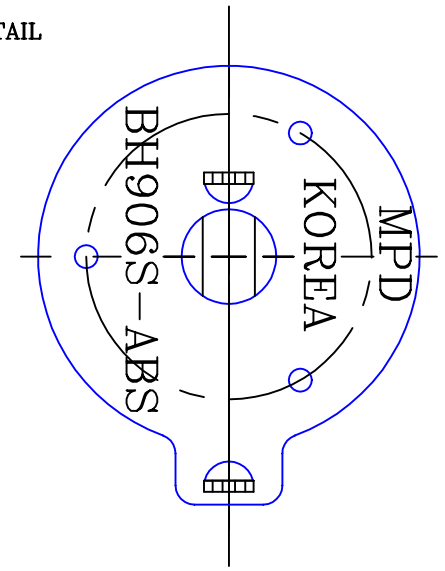

PCB LAYOUT

Date	SYM	REVISION RECORD	AUTH	DR.	CK.

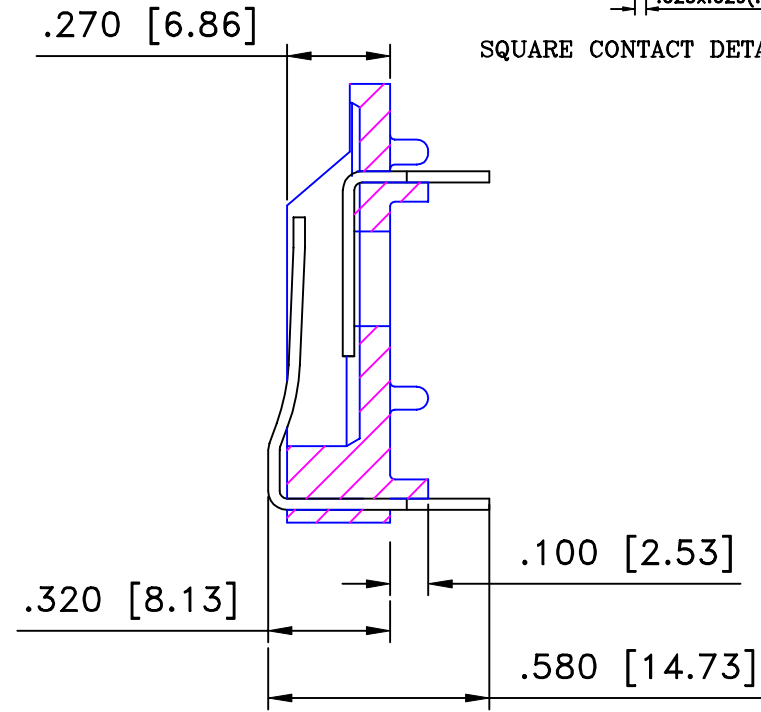
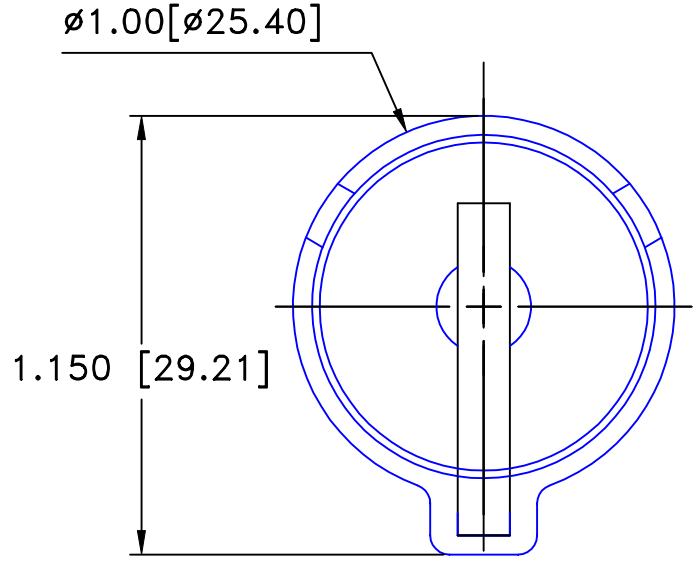
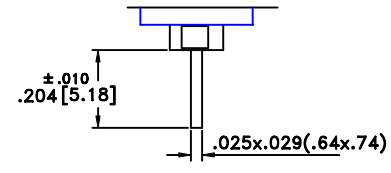
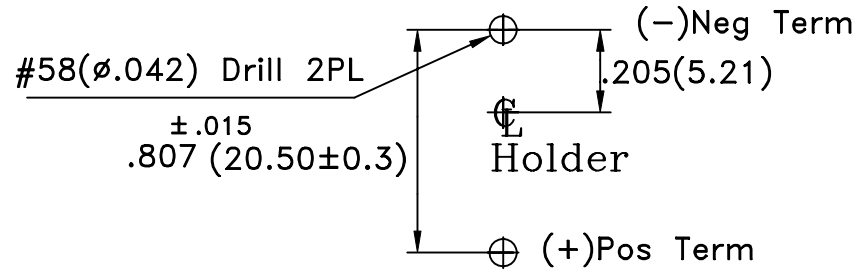

SPECIFICATIONS

- *Holder material-High Strength, Black ABS
- *Flammability rating-UL94HB, File No.E67171(M)
- *Contacts-SK5 spring steel, Nickel Plated 0.0002" thick
- *Vicat Softening Temp. 96° C per test method D-1525
- *Heat Deflection Temp. 89° C per test method D-648 unannealed 18.5kg/cm, 1/2"

Tolerance (Except as noted)	 Memory protection Devices, Inc 200 Broad Hollow Road, Farmingdale, New York 11735	Scale	Drawn By B.S.
decimal ±.5 (.020)		4=1	Approved By T.B.
Fractional ± .8 (.030)	Title CR2354 OR TWO BR2325 BATTERY		
Angular ± 3°	Date 10/20/01	Drawing Number BH906S-ABS	