



# MX1604

Size: 9V (6LR61)

## Alkaline-Manganese Dioxide Battery

Zn/MnO<sub>2</sub>

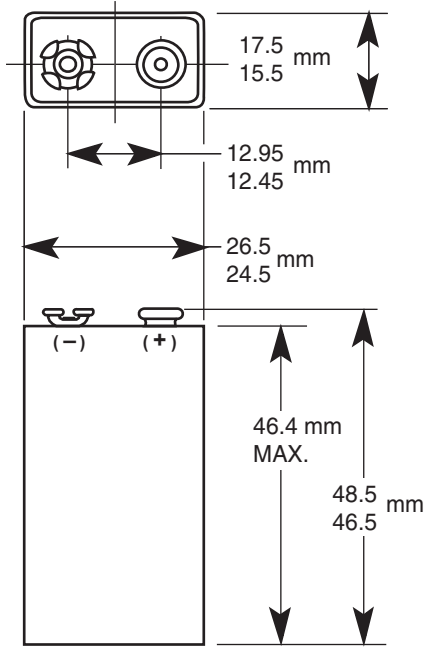

Dimensions shown are IEC/ANSI standards

<b>Nominal Voltage:</b>	9 V
<b>Nominal Internal Impedance:</b>	1,700 m-ohm @ 1kHz
<b>Average Weight:</b>	47 gm (1.7 oz.)
<b>Volume:</b>	22.8 cm <sup>3</sup> (1.39 in. <sup>3</sup> )
<b>Terminals:</b>	Miniature Snap
<b>Operating Temperature Range:</b>	-20°C to 54°C (-4°F to 130°F)
<b>NEDA/ANSI:</b>	1604A
<b>IEC:</b>	6LR61

### TYPICAL DISCHARGE CHARACTERISTICS AT 21 °C (70°F)

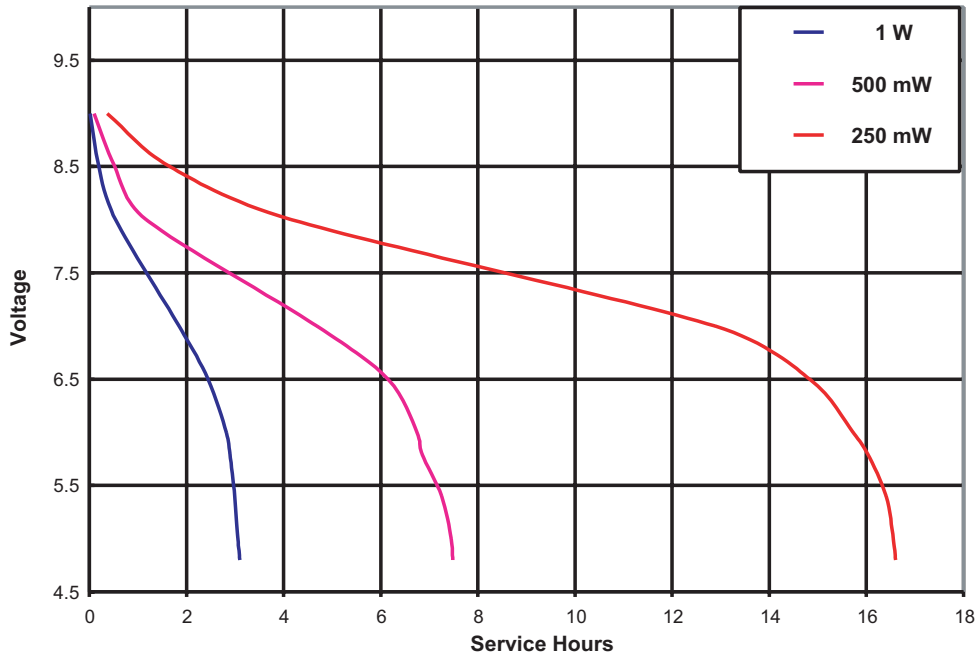

\* Delivered capacity is dependent on the applied load, operating temperature and cut-off voltage. Please refer to the charts and discharge data shown for examples of the energy / service life that the battery will provide for various load conditions.



# MX1604

Size: 9V (6LR61)  
Alkaline-Manganese Dioxide Battery

Zn/MnO<sub>2</sub>

Delivered Energy vs. Power Drain

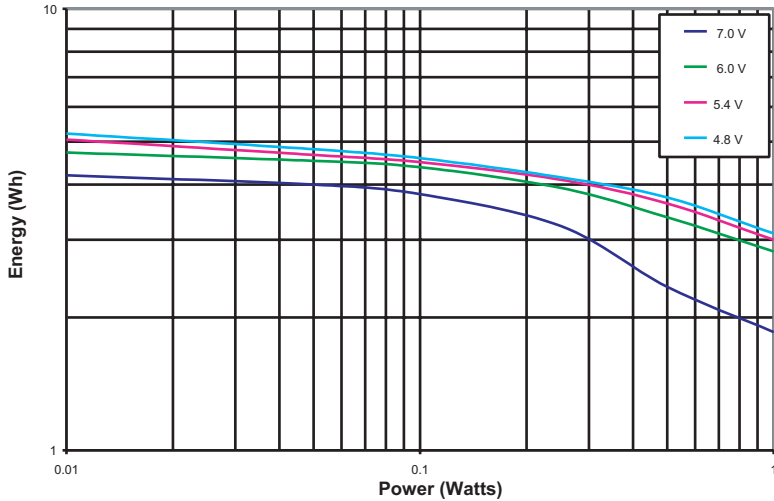

Delivered Capacity vs. Power Drain

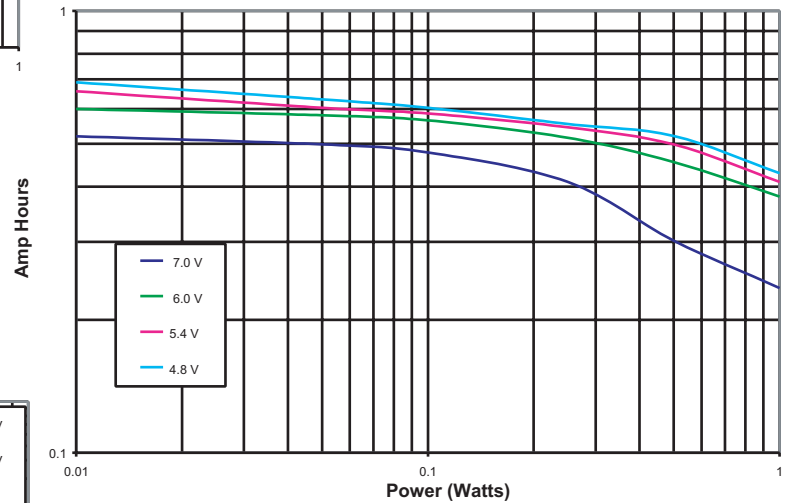

Service Hours vs. Power Drain

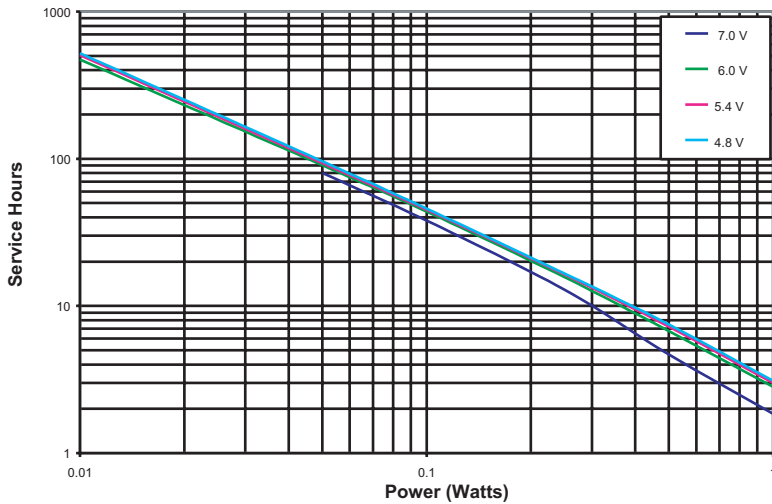

**DURACELL**  
BATTERIES

Berkshire Corporate Park  
Bethel, CT 06801 U.S.A.  
Telephone: Toll-free 1-800-544-5454  
Internet: [www.duracell.com](http://www.duracell.com)

All testing at 21°C (70°F)

\* Delivered capacity is dependent on the applied load, operating temperature and cut-off voltage. Please refer to the charts and discharge data shown for examples of the energy / service life that the battery will provide for various load conditions.