

### IFR12-160TB-Y (12.8V 16Ah)

Standard Model

#### SPECIFICATIONS

<b>Nominal Voltage</b>	12.8V
<b>Nominal Capacity @5hr Rate</b>	16Ah
<b>Watt-hour</b>	204.8Wh
<b>Dimensions</b>	
<b>Length</b>	168 mm
<b>Width</b>	128 mm
<b>Height</b>	75 mm
<b>Weight</b>	2.1±0.1kg
<b>Internal Resistance (at 1KHz)</b>	≤40mΩ
<b>Charge @25°C</b>	
<b>Standard Charge Current</b>	3A
<b>Maximum Charge Current</b>	5A
<b>Cut-off Voltage</b>	14.4V (14.6V Max)
<b>Discharge @25°C</b>	
<b>Standard Discharge Current</b>	3.2A
<b>Max. Continuous Discharge</b>	16A
<b>Cut-off Voltage</b>	10.0V (8.8V min)
<b>Assembly</b>	26650 - 4S5P
<b>Operating Temp</b>	
<b>Charge</b>	+5 - +45°C
<b>Discharge</b>	-10 - +60°C
<b>Storage</b>	0 - +40°C
<b>Humidity</b>	RH≤85%
<b>Case Material</b>	ABS
<b>Termination</b>	T Bar to ADS + Lotus Seat
<b>Fuel Gauge</b>	N/A
<b>Communications Port</b>	N/A

Protection: Overcharge protection, over discharge protection, over temperature protection, over current protection, balancing function

#### BUILT IN PROTECTION

All Drypower Rechargeable Lithium batteries adhere to strict safety guidelines by incorporating Battery Management Systems (BMS) that include protection components such as:

- Integrated Circuit (IC)
- Thermistor
- MOSFET
- Protection Circuit Module (PCM)
- Fuse

The BMS in each Drypower battery helps to:

1. Maintain safety for users.
2. Prevent damage to equipment and property.
3. Eliminate concerns about use of the wrong type of charger.
4. Minimise the risk of overdischarge causing damaging.
5. Provide short circuit and overcharge protection.



Drypower Rechargeable Lithium (LiFePO<sub>4</sub>) batteries offer unmatched performance in a wide range of industrial or high drain applications.

With its impressive cycle life of up to 2000 cycles, implementing Drypower batteries drastically reduces overall total cost of ownership compared to SLA batteries.

#### DIMENSIONS

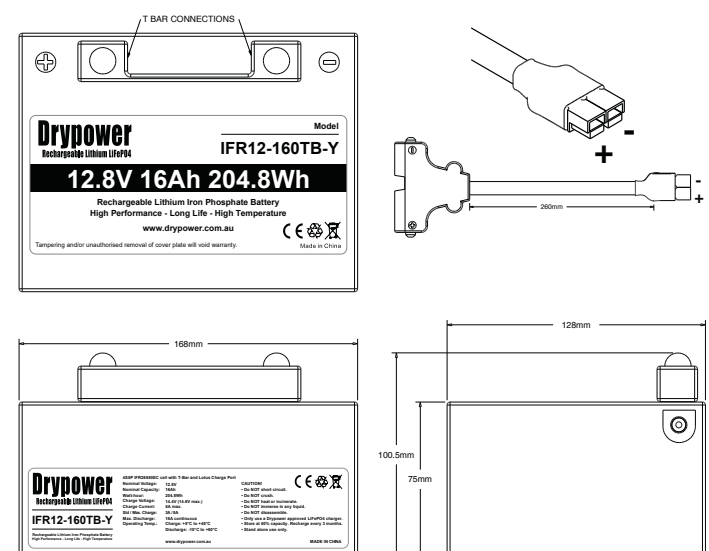

T-Bar to Anderson lead included.

**Discharge Voltage Profiles @ 0.5C Discharge Rate**  
Various Ambient Temperatures

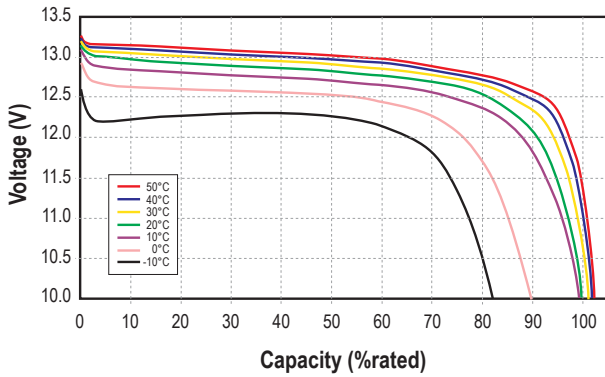

**Discharge Capacity Performance**

Charged: 0.5C to 14.6V, CV@14.6 to 1A  
Discharged: 0.5C to 10.5V

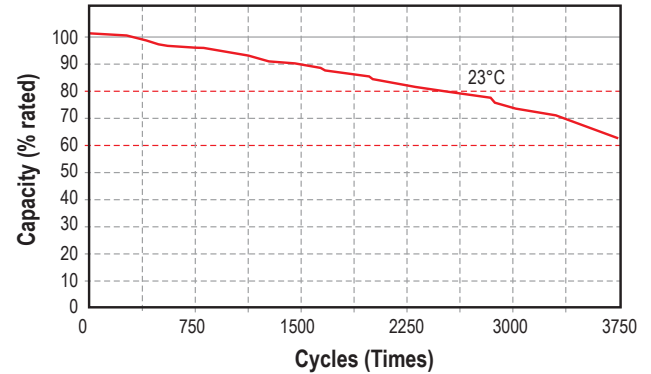

**Discharge Voltage Profiles @ Various Temperatures**  
23°C Ambient Temperatures

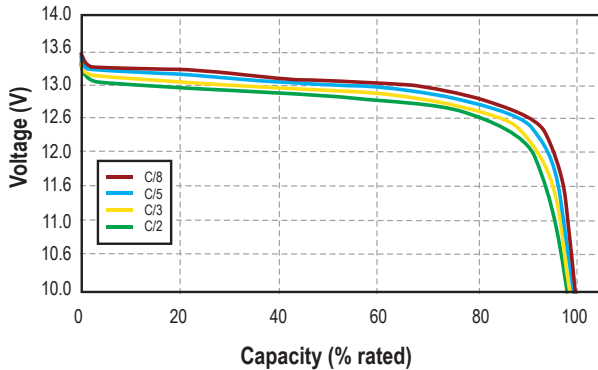

**Typical Voltage Profiles & SOC Profiles @ 0.5C Charging**  
23°C Ambient Temperatures

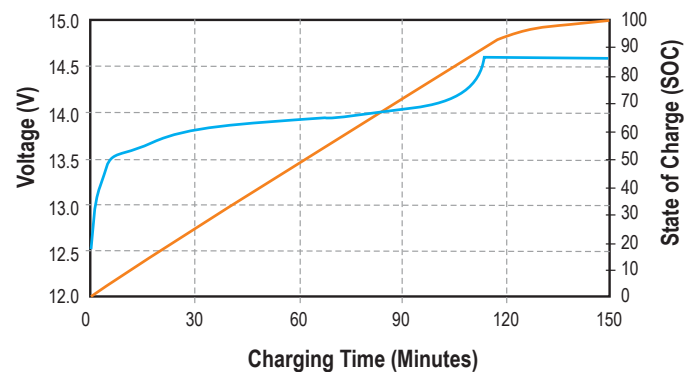

## FEATURES & BENEFITS



### High cycle life

>2000 cycles @80% DoD for effectively lower total cost of ownership.



### Lightweight

Drypower Lithium batteries provide more Wh/Kg while also being up to 1/3 the weight of its SLA equivalent.



### Built in circuit protection

Battery Management Systems (BMS) are incorporated to maintain safety and prevent damage.



### Better storage

12-18+ months thanks to its extremely low self discharge (LSD) rate and no risk of sulphation.



### Quickly recharge

Save time and increase productivity with less down time thanks to superior charge/discharge efficiency.



### Extreme heat tolerance

Suitable for use in a wider range of applications where ambient temperature is unusually high: up to +60°C.



### Longer service life

Low maintenance batteries with stable chemistry. Easily monitor state of health (SoH) of smart models.

## SUITABLE APPLICATIONS

Lithium Iron Phosphate can be used in any application that would normally use Lead Acid, GEL or AGM type batteries\*. LiFePO4 in 4S = 12.8V and 8S = 25.6V is closest to Lead Acid equivalents of the lithium rechargeable types.

Suitable applications include caravan, marine, golf carts & buggies, solar storage, remote monitoring, switching applications and more.

*\*Exceptions may apply so please consult with a Drypower technical expert for more information regarding your application.*

## CAUTIONS

- Do NOT short circuit, crush or disassemble.
- Do NOT heat or incinerate.
- Do NOT immerse in any liquid.
- Only use a Drypower approved LiFePO4 charger.
- Store at 50% capacity. Recharge every 3 months. The storage area should be clean, cool, dry and ventilated.