

PostMount 2-A for XL Panels Installation Guide

Code-Compliant Planning and Installation Guide V1.0

Complying with AS/NZS1170.2: 2011 ADMT 4-2016



1. Introduction

Clenergy PV-ezRack PostMount 2-A for XL Panels (up to 2100 x 1100 mm) is a ground mounting system suitable for large scale commercial and utility scale installations. PV-ezRack PostMount 2-A for XL Panels has been developed to fit any PV module in the outdoors and uneven ground areas. PV-ezRack PostMount 2-A for XL Panels have good compatibility for the different region via the angle adjustment (10°~60°). Using high quality engineered components PostMount 2-A for XL Panels saves developers and installers, time and money when delivering large scale projects.

Please review this manual thoroughly before installing PostMount 2-A for XL Panels. This manual provides the following contents:

- (1) Installation planning;
- (2) Installation instructions.

List of Contents

Introduction	01
Tools & Components	02
System Overview	03
Installation Instruction	06
Warranty	12
Certification Letter	13

The PV-ezRack PostMount 2-A for XL Panels parts, when installed in accordance with this guide, will be structurally adequate and meet the AS/NZS1170.2:2011 Admt 4-2016 standard. During installation, and especially when working on the ground, please comply with the appropriate occupational health and safety regulations. Please also pay attention to other relevant regulations in your local region. Please check that you are using the latest version of the installation manual by contacting Clenergy via email on www.clenergy.com.cn or contacting your local distributor.

The installer is solely responsible for:

- Complying with all applicable local or national building codes, including any updates that may supersede this manual;
- Ensuring that PV-ezRack and other products are appropriate for the particular installation and the installation environment;
- Using only PV-ezRack parts and installer supplied parts as specified by PV-ezRack project plan (substitution of parts may void the warranty and invalidate the letter of certification);
- Recycling: Recycle: according to the local relative statute;
- Ensuring that there are no less than two professionals working on panel installation;
- Ensuring the installation of related electrical equipment is performed by licenced electricians;
- Ensuring safe installation of all electrical aspects of the PV array including providing adequate earth bonding of the PV array and PV-ezRack® PostMount components as required in AS/NZS 5033-2014 ADMT 2 2-2018.

Tools & Components

2. Tools & Components

2.1 Tools

Tools



Allen Key 6 mm



Spanner



Torque Wrench



5m Tape

2.2 Components

Components



C-U/30/46-G
Universal Clamp



ER-R-ECO/2100
ECO Rail, length 2100mm



ER-AP-PM2/A-LP
PM2-A Kit



ER-P-102/2600
Pipe



SC-PM2/3/4/A
Steel Cap



ER-RT-70/394
Adjustable Tube



ER-RT-70/1300
Rectangular Tube-
Master



ER-RT-50/1400
Rectangular Tube-
Landscape



EZ-GL-ST
Grounding Lug

3. System Overview

3.1 Overview of PV-ezRack PostMount 2-A for XL Panels

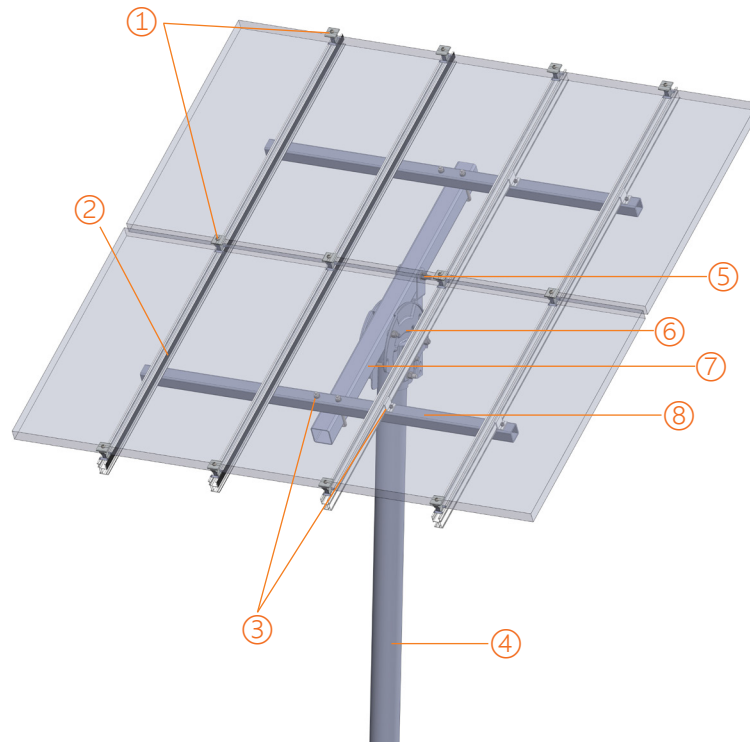

- ① Universal Clamp
- ② ECO Rail
- ③ PM2-A Kit
- ④ Pipe
- ⑤ Adjustable Tube
- ⑥ Steel Cap
- ⑦ Rectangular Tube-Master
- ⑧ Rectangular Tube- Landscape

Side view drawing of PV-ezRack PostMount 2-A for XL Panels is shown below. The panels tilt angle and embedment depth below are for reference only. Please refer to Certificate Letter to obtain the certified max panels tilt angle and min embedment depth for different wind regions and different soil types.

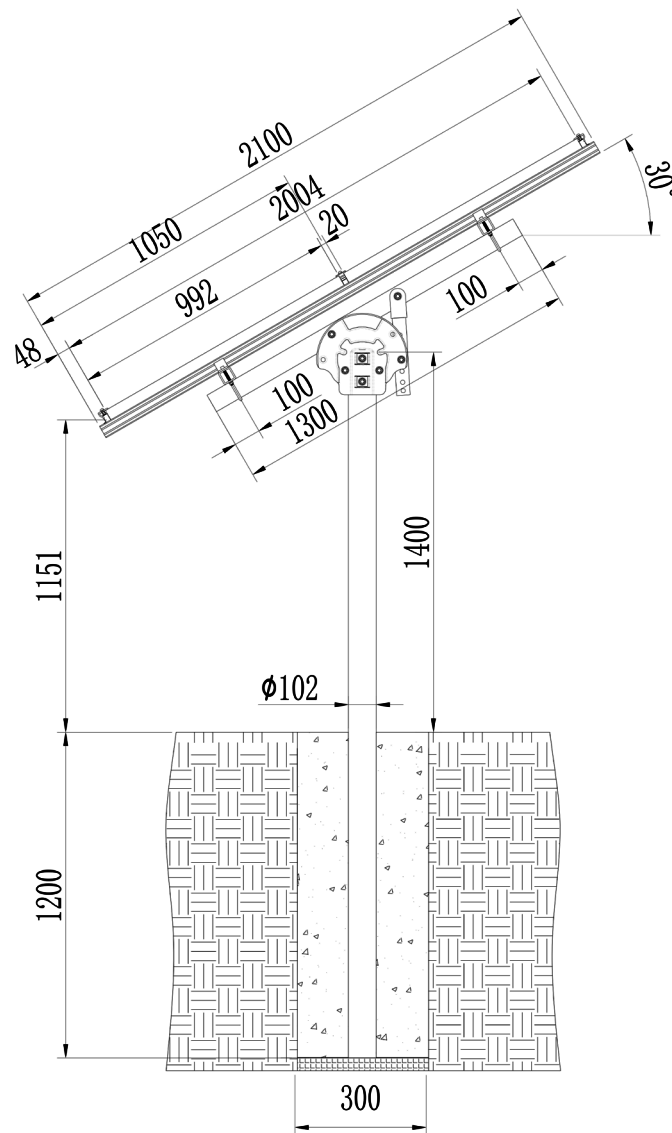

3.2 Precautionary Measures for Stainless-Steel Fastener Installation

Improper operation may lead to the deadlock of bolts and nuts. Follow the steps below to reduce this risk.

3.2.1 Reduce the friction coefficient

- (1) Ensure that the thread surface is clean (no dirt or contaminant).
- (2) Apply lubricant (grease or 40# engine oil) to fasteners prior to tightening to avoid galling or seizing in the threads.

3.2.2 General installation instructions

- (1) Apply force to fasteners in the direction of thread.
- (2) Apply force uniformly to maintain required torque.
- (3) Professional tools and tool belts are recommended.
- (4) Avoid using electric tools for final tightening.
- (5) Avoid working at high temperatures.

3.2.3 Safe Torques

Please refer to safe torques defined in this guide as shown in the figure below. If power tools are required, Clenergy recommends the use of low speed only. High speed and impact drivers increase the risk of bolt galling (deadlock). If deadlock occurs and you need to cut fasteners, please make sure that there is no load on the fastener before you cut it. Avoid damaging the anodized or galvanized surfaces.

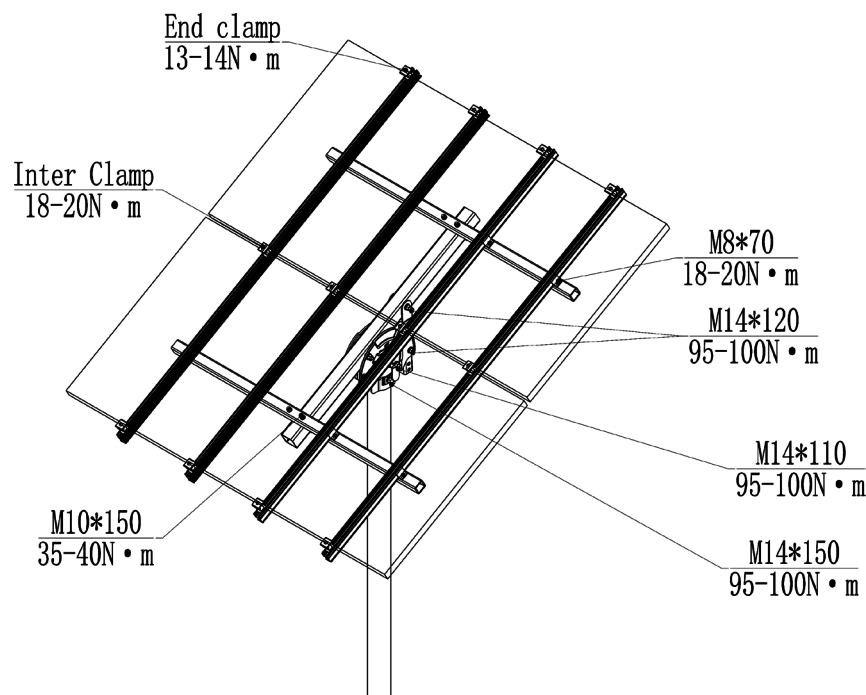

3.3 Installation Dimensions

All drawings and dimensions in this installation guide are for generic reference. The PV-ezRack PostMount 2-A for XL Panels is to be optimized to suit specific conditions for each project and documented in engineering drawings. As a result, major components of the PV-ezRack PostMount 2-A for XL Panels may be provided in sectional sizes and lengths that vary from those shown in this guide. The installation operations detailed in this instruction guide remain the same regardless of the component size. In case you need to do any on-site modifications or alteration of the system in a way that would be different from engineering drawings, please provide marked up drawings/sketches for Clenergy's review prior to modification for comment and approval.

Installation Instruction

4. Installation Instruction

4.1 Pipe Installation

Dig a hole with the diameter of 300 mm.

Place the pipe into the middle of the hole and fill it with concrete (min 25 MPa strength). Maintain the position of the pipe. The allowed vertical tolerance is $\pm 2^\circ$. Keep the axle of the 2- $\varnothing 16$ holes parallel to East-West; keep the vertical angle deviation within $\pm 5^\circ$. For more than one system on one site maintain all the axles of 2- $\varnothing 16$ holes aligned.

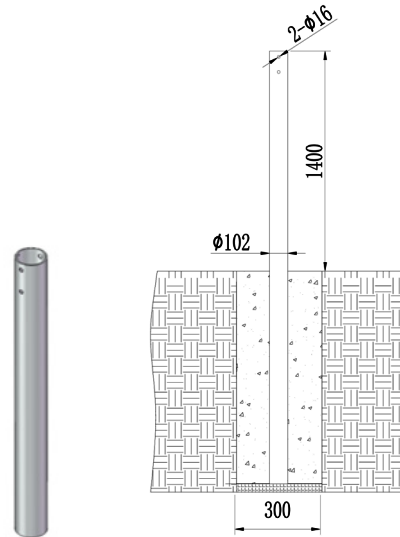

4.2 Steel Cap Installation

Connect the Pipe to the corrugated washer and Steel Cap Assembly with M14*150 hexagonal bolt, plain washer 14, spring washer 14, M14 nut.
Combine two Steel Caps with M14*110 hexagonal bolt, plain washer 14, spring washer 14, M14 hex nut.

Note:

1. Do not fasten the Bolt prior to complete the assembly of PM-A Rectangular Tube-Master.
2. Keep all the Bolt head aligned.

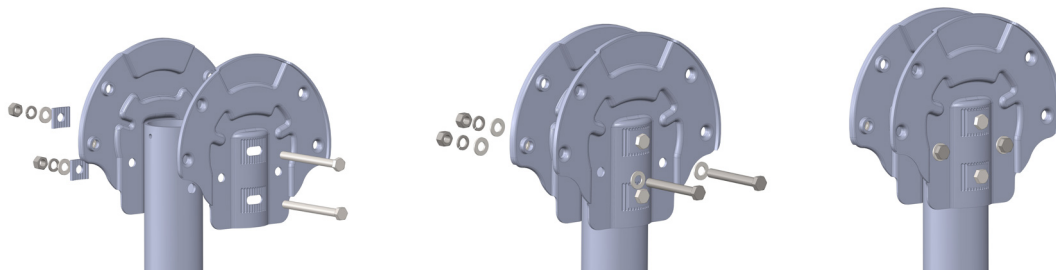

4.3 Rectangular Tube-Master and Adjustable Tube Installation

4.3.1 Fix the Rectangular Tube-Master at Steel Cap Assembly with M14*120 hex bolt, M14 nut, plain washer 14, and spring washer 14. See the mark ① .

4.3.2 Fix the Adjustable Tube at Rectangular Tube-Master with M14*120 hex bolt , plain washer 14, and spring washer 14, M14 nut. See the mark ② .

4.3.3 Fix the Adjustable Tube at Steel Cap Assembly with M14*120 hex bolt, M14 nut, plain washer 14, and spring washer 14. See the mark ③ .

Realized the angle adjustment by position the bolt in the different holes.

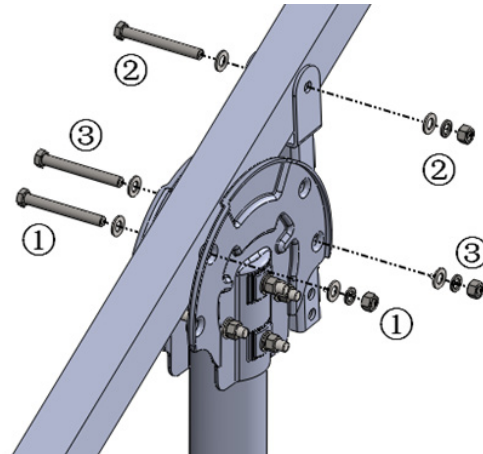

4.3.4 Fasten the Steel Cap Assembly to Pipe with M14*150, M14*110 Hex Bolt, keep the Rectangular Tube-Master parallel to the south-north by adjust the Steel Cap Assembly.

Recommended torque for M14 bolts is 95~100 N·m.

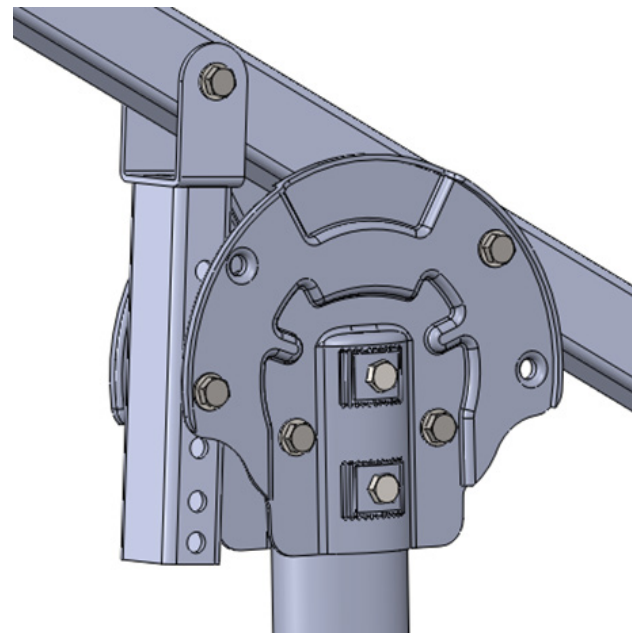

Note:

1: Adjust the angle of the allation, the angle of the Rectangular Tube-Master with 10° (6 holes from up to bottom corresponds to 10° to 60° tilt angle) in order to make the assembly process run smooth.

2: Using the adjustable washer to avoid the gap between the Rectangular Tube-Master and the Adjustable Tube. Unreliable connection is forbidden.

4.4 Rectangular Tube- Landscape Installation

4.4.1 Fix the 2 pcs Rectangular Tube-Landscapes at Rectangular Tube-Master with 2 pcs U-bolts, 4 pcs M10 nuts , 4 pcs spring washers 10, and 4 pcs plain washers 10. Do not fasten the Nut until 2 Rectangular Tube-Landscapes aligned.

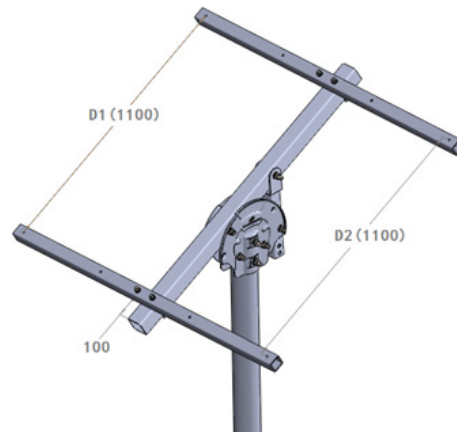

Note: Adjust the Rectangular Tube-Landscapes until the dimension D1=D2.

Recommended torque for M10 bolts is 35~40 N·m.

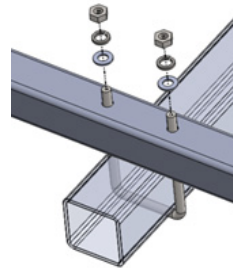

4.4.2 Preassemble the Cross Connection Clamp at the Rectangular Tube-Master with M8*70 hex bolts, plain washer 8, spring washer 8, and M8 nut as shown in the figure on the right.

Note: Do not fasten the M8*70 hex bolt in order to make other clamp fit well.

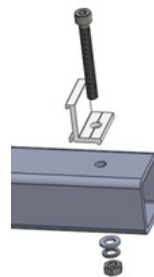

4.5 ECO Rail Installation

Uplift the Cross Connection Clamp in the certain angle. Click the Clamp into the ECO Rail. Position the Rail in the middle of the Rectangular Tube-Master, and then fasten the M8*70 bolt.

Recommended torque for M8 bolts is 18~20 N·m.

Note: ECO Rail of 2100 mm is a standard length in this system, which can be suitable for up to 1002 mm wide panel. If the panels are over 1002 mm (less than 1100 mm) wide, the required minimum rail length is:

(panel width-1002)*2+2100 (mm).

For example, panels are 1050 mm wide. The required minimum rail length is $(1050-1002)*2+2100 = 2196$ mm. For convenience, the rail length is rounded up to 2200 mm (multiple of 50 mm).

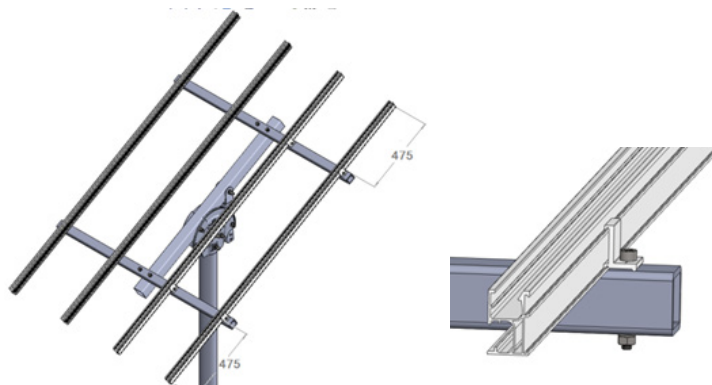

4.6 PV Module Installation

4.6.1 Fix the PV panel to Rail, via Universal Inter Clamps and End Clamps step by step until all the panels complete.

Recommended torque for M8 bolts is 18~20 N·m

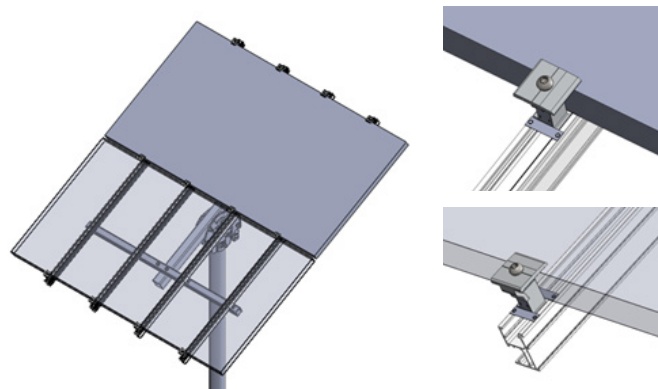

Installation Instruction

Note: The Universal Clamp can be used both as a End Clamp and a Inter Clamp, and the height can be adjusted from 30 to 46 mm.

When the side of the Universal Clamp close to the narrow side of the Universal Clamp Buckle, it can be used as End Clamp, and when the side of the universal clamp close to the wide side of the Universal Clamp Buckle, it can be used as inter clamp, as shown in the figure below. The Universal Clamp can be directly rotated to the position of required End or Inter Clamp.

Recommended torque for M8 bolts when it is Inter Clamp is 18~20 N·m

Recommended torque for M8 bolts when it is End Clamp is 13~14 N·m

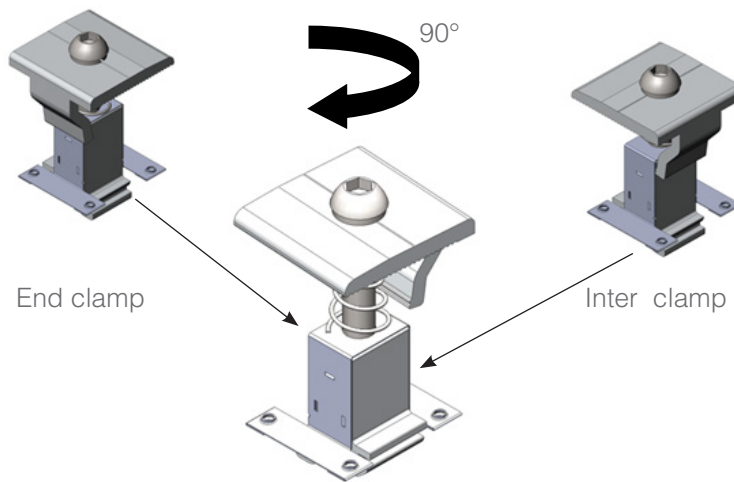

4.6.2 Apply one pre-assembled Grounding Lug per Rail. Click the Grounding Lug into to the rail channel and insert the Copper Wire. (the maximum size is 4 mm² or similar) Fasten the bolt M6*14 with 5~6 N.m and the bolt M8*25 with 16~20 N.m .Copper Pipe will be supplied for the case that using small size Copper Wire.

Installation Instruction

There are three solutions for Grounding Lug installation.

-Solution 1 Fix the Grounding Lug at the end of Rail as shown in the figure on the right.

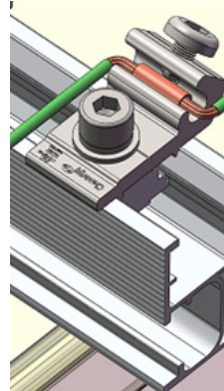

-Solution 2 Fix the Grounding Lug at the Rail where just under the PV Module as shown in the figure on the right.

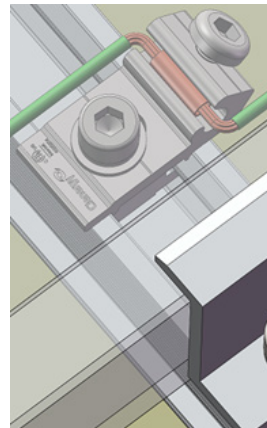

-Solution 3 Fix the Grounding Lug at the side channel of Rail as shown in the figure on the right.



5. Warranty

10 year limited Product Warranty, 5 year limited Finish Warranty

Clenergy (Xiamen) Technology co. Ltd warrants to the original purchaser ("Purchaser") of product(s) that it manufactures ("Product") at the original installation site that the Product shall be free from defects in material and workmanship for a period of ten (10) years, except for the anodised finish, which finish shall be free from visible peeling, or cracking or chalking under normal atmospheric conditions for a period of five (5) years, from the earlier of 1) the date the installation of the Product is completed, or 2) 30 days after the purchase of the Product by the original Purchaser ("Finish Warranty").

The Finish Warranty does not apply to any foreign residue deposited on the finish. All installations in corrosive atmospheric conditions are excluded. The Finish Warranty is VOID if the practices specified by AAMA 609 & 610-02 – "Cleaning and Maintenance for Architecturally Finished Aluminum" (www.aamanet.org) are not followed by Purchaser. This Warranty does not cover damage to the Product that occurs during its shipment, storage, or installation.

This Warranty shall be VOID if installation of the Product is not performed in accordance with Clenergy's written installation instructions, or if the Product has been modified, repaired, or reworked in a manner not previously authorized by Clenergy IN WRITING, or if the Product is installed in an environment for which it was not designed. Clenergy shall not be liable for consequential, contingent or incidental damages arising out of the use of the Product by Purchaser under any circumstances.

If within the specified Warranty periods the Product shall be reasonably proven to be defective, then Clenergy shall repair or replace the defective Product, or any part thereof, at Clenergy's sole discretion. Such repair or replacement shall completely satisfy and discharge all of Clenergy's liability with respect to this limited Warranty. Under no circumstances shall Clenergy be liable for special, indirect or consequential damages arising out of or related to use by Purchaser of the Product.

Manufacturers of related items, such as PV modules and flashings, may provide written warranties of their own. Clenergy's limited Warranty covers only its Product, and not any related items.

Certification Letter



21 January 2019

Clenergy Australia
1/10 Duerdin Street
Clayton, VIC 3168

Array Frame Engineering Certificate

Postmount PM2-A/2100 Installation

MW Engineering Melbourne Pty Ltd, being Structural Engineers within the meaning of Australian and NZ Building Regulations, have carried out a structural design check of the PV-ezRack Postmount PM2-A/2100 within Australia. The design check has been based on the information in the *PV-ezRack PM2-A/2100 Planning and Installation Guide* and schematic drawings of the system components, provided by Clenergy Australia.

Part number	Description
ER-R-ECO/2100	PV-ezRack ECO Rail 2100mm
ER-RT-50/1400	PV-ezRack PM2-A/PM3-A, Rectangular Tube-Landscape L1400*50*50*T4
ER-RT-70/1300	PV-ezRack PM2-A, Rectangular Tube-Master L1300*70*70*T4
ER-RT-70/394	PV-ezRack (PM3-A,PM4-A), Adjustable Tube 70*50*394
ER-P-102/2600	Pipe Diameter \varnothing 102*2600*T6 (PM3-A,4-A Pole)
SC-PM2/3/4/A	PV-ezRack (PM2-A,PM3-A,PM4-A), Steel Cap Assembly
C-U/30/46-G	PV-ezRack, Universal Clamp for Frame Height 30-46mm with Grounding Clip

We find the Postmount PM2-A/2100 to be structurally sufficient for Australian and New Zealand use, based on the following conditions:

- Wind Loads to AS/NZ1170.2:2011, Amendment 4-2016:
 - Wind Terrain Category: 2;
 - Wind average recurrence interval of 100 years- For ultimate state, 25 years-service-ability;
 - Wind region A, B, C & D;

Maximum Tilt Angle Options

	Wind Region			
	Region A	Region B	Region C	Region D
Wind speed (m/s)	41	48	59	73
Maximum tilt angle (°)	60	20	10	10
Soil Type	Post Embedded in concrete pier: 300 mm diameter concrete piers minimum depth (m)			
Hard class soil [Gravels; dry (hard) clays]	0.75	0.63	0.73	0.84
Very Firm class soil [Dry (Stiff) clays; clayey sands; coarse sands; compact sands]	0.81	0.67	0.76	0.89
Firm class soil [Damp clays; sandy clays; damp sands]	0.90	0.75	0.85	0.99
Soft class soil [wet clays; silty loams; wet loose sands]	1.05	0.88	1.02	1.18

Notes:

1. Terrain Category 2 (TC2) refers to open terrain, including grassland, with well-scattered obstructions having heights generally from 1.5m to 5m, with no more than two obstructions per hectare. This certificate will only cover Postmount PM2-A/2100 installed on TC2.
2. Panel weight calculated: 28kg
3. Solar Panels structural check by others.
4. Other piers dimensions are possible, contact Clenergy, if required.
5. For concrete pier foundations, use 25Mpa strength concrete (minimum).
6. The scope of this certification is for projects located at a maximum altitude of 100m above sea level. No snow loads have been assessed.
7. If depth of footing is less than length of post below ground (embedment depth of post) the post must be cut to suit the new level.



REF: CL-10127-S
Internal REF: 00140

8. Footing depths are for reference only. The characteristics of the soil must be checked on site by a technical expert. A soil report assessment is always recommended and Clenergy must be informed on the outcome of the soil report.

Construction is to be carried out strictly in accordance with the instruction manual. This work was designed in accordance with the provisions of Australian Building Regulations and in accordance with sound, widely accepted engineering principles.

Should you have any queries, do not hesitate to contact us.

Best Regards,

A handwritten signature in black ink, appearing to read "A. Escobar", with a stylized flourish at the end.

Alberto Escobar
Civil/Structural Engineer
BEng MIEAust NER
BRP EC 46542
RPEQ 18759
info@mwengineering.melbourne



Worldwide Network



Clenergy Australia

1/10 Duerdin Street, Clayton VIC 3168 Australia
 Tel: +61 3 9239 8088 Fax: +61 3 9239 8024
 E-mail: sales@clenergy.com.au www.clenergy.com.au

Clenergy China

999-1009 Min'an Rd, Huoju Hi-tech Ind. Dev. Zone
 Xiang'an District 361101, Xiamen, Fujian, China
 Tel: +86 592 311 0088 Fax: +86 592 599 5028
 E-mail: sales@clenergy.com.cn www.clenergy.com.cn

Clenergy EMEA

Esplanade 41, 20354 Hamburg, Germany
 Tel: +49 (0) 40 3562 389 00
 E-mail: sales.emea@clenergy.com

Clenergy Japan

Nittochi Yamashita Building 5th Floor
 23 Yamashita-cho, Yokohama, 231-0023 Japan
 Tel: +81 45 228 8226 Fax: +81 45 228 8316
 E-mail: sales@clenergy.co.jp www.clenergy.jp

Clenergy Philippines

145 Yakal St., San Antonio village, Makati City, Philippines
 Tel: +63 977 8407240
 E-mail: sales_ph@clenergy.com www.clenergy.ph

Clenergy Thailand

9/2, 5th Floor, Vorasin Building, Soi Yasoob 2, Viphavadee-Rungsit
 Road, Chomphon Sub-district, Chatuchak District, Bangkok 10900
 Tel: +66 63 228 0200, +66 81 969 5152
 E-mail: sales_th@clenergy.com, support_th@clenergy.com

Clenergy Singapore

24 Raffles Place #28-01 Clifford Centre Singapore 048621
 Tel: +65 9743 1425
 E-mail: vincent.chan@clenergy.com

Clenergy Vietnam

Tel: +86 592 3110095
 E-mail: sales_vietnam@clenergy.com;
 susie.chen@clenergy.com;
 ducnguyen@clenergy.com

