



12V

550W

SLA

UPS
AGM

12SB550WHR-FR

Rechargeable AGM Sealed Lead Acid Battery

SPECIFICATIONS

Nominal Voltage	12V
Nominal Power	
15 min rate	550W/cell to 1.67V/cell
Nominal Capacity	
20 hour rate (7.0A to 10.50V)	140Ah
8 hour rate (15.0A to 10.50V)	120Ah
5 hour rate (23.8A to 10.20V)	119Ah
Weight	Approx. 45.5kg
Internal Resistance (at 1KHz)	Approx. 3.5mΩ
Maximum Discharge Current (5 secs)	1400A
Short Circuit Current	4775A
Charge Methods at 25°C	
Maximum Charging Current	45A
Boost Charging Voltage	14.1V to 14.4V
Boost Charge Time	8-9 hrs
Float Charging Voltage	13.5V to 13.65V
Coefficient -3.0mV/°C/Cell	

Operating Temperature Range

Charge	-15°C to 40°C
Discharge	-15°C to 50°C
Storage	-15°C to 40°C

Charge Retention (Shelf Life) at 20°C

1 month	98%
3 months	96%
6 months	94%

Case Material: UL94 V-0 Flame Retardant

Termination: F8 (M6 Bolt)

Torque Value of Terminal Hardware

Recommended Torque Value	M6: 7 N-m (71kgf-cm)
Max. Allowable Torque Value	M6: 10 N-m (102kgf-cm)

Design Life: 10-12 years

Classified as a non-spillable battery.

Approved for transportation by:

- Air (IATA/ICAO provision A67)
- Road
- Sea (per IMDG Special Provision 238)



Barcode



9319632521434



UL94 V-0
FLAME RETARDANT
CASE

DIMENSIONS

mm (inch)

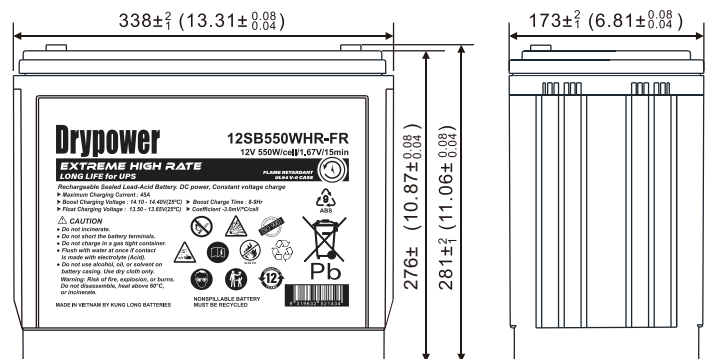
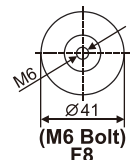
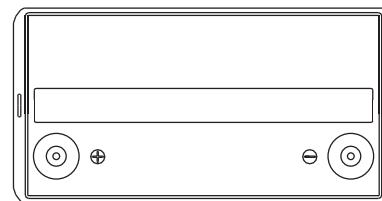

CHARACTERISTICS CHARTS

Effect of Temperature on Capacity 25°C (77°F)

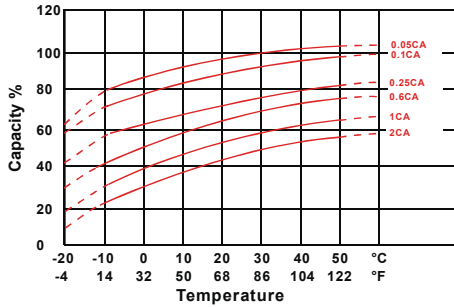

Capacity Retention Characteristic

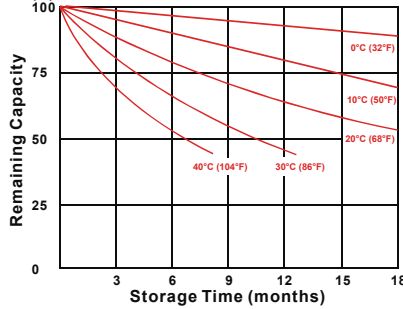

Trickle (or float) Service Life

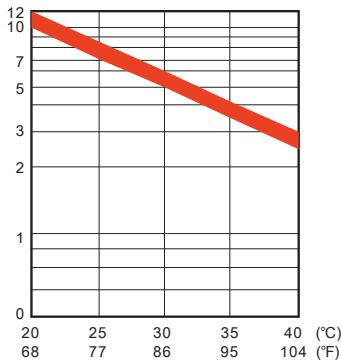

Discharge Time VS. Discharge Current (25°C)

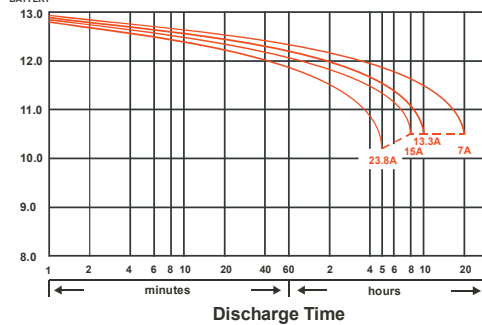

FEATURES & BENEFITS

- ◆ Industry leading 99.99% pure lead content for superior service life and dependable performance.
- ◆ Specially formulated solder paste to ensure reliable power delivery.
- ◆ Maintenance free technology and non-spillable design.
- ◆ Special grid frame alloy design with outstanding anti-corrosion performance.
- ◆ Higher percentage of tin content compared with the industry standard. Tin extends battery standby life by minimising sulphation (corrosion) especially at higher temperatures.
- ◆ Manufactured by Kung Long Battery (KLB) at facilities in Taiwan and Vietnam. KLB is a leading manufacturer and complies with relevant international quality standards including ISO9001, CE ETL9000, UL1989, OHSAS18001 and ISO17025. KLB supports Green Sustainable supply chain practices.



PERFORMANCE DATA

Discharge Rates in Watts to Various End Voltages at 25°C (77°F)

End Voltage		1.85V	1.80V	1.75V	1.70V	1.67V	1.65V	1.60V
2	min	808	926	1035	1144	1234	1324	1400
4	min	800	887	957	1012	1052	1082	1112
5	min	698	803	893	963	1023	1063	1096
6	min	672	742	797	837	877	892	907
8	min	637	695	738	773	801	819	834
10	min	570	630	672	705	738	751	761
15	min	475	515	530	543	553	558	562
20	min	426	440	450	457	462	465	468
30	min	300	312	317	322	325	328	330
40	min	245	249	252	254	256	257	258
45	min	234	239	241	243	245	246	247
60	min	151	163	171	173	175	176	177
90	min	101	109	114	119	124	127	130
120	min	84.3	87.8	90.3	91.6	92.5	93.3	93.8
180	min	66.2	68.1	69.3	70.1	70.5	70.7	70.9
240	min	49.3	50.9	51.7	52.1	52.4	52.6	52.8
300	min	42.8	44.2	45.1	45.4	45.7	45.9	46.1
480	min	26.3	27.5	28.4	28.9	29.4	29.7	30
600	min	24	25.2	25.5	25.7	25.8	25.9	25.9
1200	min	12.7	13	13.5	13.7	13.8	13.9	14

Discharge Rates in Amperes to Various End Voltages at 25°C (77°F)

End Voltage		1.85V	1.80V	1.75V	1.70V	1.67V	1.65V	1.60V
2	min	450	530	598	661	713	765	809
4	min	388	463	527	564	598	630	660
5	min	380	445	506	527	560	580	598
6	min	372	427	467	506	527	542	550
8	min	320	358	392	422	447	467	482
10	min	285	332	372	380	385	388	390
15	min	236	261	281	301	309	314	317
20	min	200	219	234	242	247	252	255
30	min	142	157	166	171	174	177	180
40	min	125	131	133	135	137	138	139
45	min	117	122	127	128	128	129	129
60	min	77.5	79.4	81	81.2	81.4	81.6	81.7
90	min	62.2	64	65.4	65.8	66	66.2	66.4
120	min	45.5	48.4	50	50.8	51.2	51.6	51.8
180	min	29.8	33	33.3	33.6	33.8	34	34.2
240	min	25.3	27.5	29	29.7	30	30.2	30.4
300	min	22.7	24.6	25.2	25.5	25.7	25.8	25.9
480	min	14.9	15	15.9	16	16.1	16.1	16.2
600	min	13.2	14	14.2	14.3	14.4	14.4	14.5
1200	min	7.12	7.3	7.4	7.41	7.42	7.43	7.43

All data on the spec. sheet is an average value:

The tolerance range : X < 6min (+15%~-15%), 6min ≤ X < 10min (+12%~-12%), 10min ≤ X < 60min (+8%~-8%), X ≥ 60min (+5%~-5%)

Performance may vary depending on application. All specifications are correct at time of creation. All specifications and operation conditions contained in this datasheet are subject to change or improvement without prior notice to the user. This data is for evaluation purposes only. No guarantee is intended or implied by this data. For clarification and updated information, please contact us. Dec2023