



120mm square replacement fan

for Enepower EBC25 series storage cabinets. 107CFM Rated.

TECHNICAL SPECIFICATIONS

Model	EBC25H-107FAN
Rated Voltage	48VDC
Start-up Voltage	30VDC (25°C Switch power ON/OFF)
Operating Voltage	48VDC
Rated Speed	3000rpm ±10%
Rated Current	0.13A ±10%
Rated Power	6.24W ±10%
Rated Airflow	107.46CFM
Operating Temp. Range	Temperature: -10°C ~70°C
	Humidity: 15%~ 90% RH (Frost Eliminated)
Storage Temp. Range	Temperature: -40°C ~35°C
	Humidity: 15%~ 90% RH (Frost Eliminated)
Life Expectancy	3-5W hrs at 40°C
Noise Level	46.2dB max
Rotating Direction	Clockwise (From Label side)
IP Rating	IP68
Certification	CE

Electrical Specification

Polarity Protection	<ul style="list-style-type: none"> The fan includes reverse polarity protection. When Vcc and GND are connected in reverse, the circuit will not conduct. The fan will not be damaged if reverse polarity is applied for up to 5 seconds.
Insulation Resistance	10MΩ between bare wire and outer frame, 500VDC/min
Dielectric Strength	5mA max/measured between bare wire and frame, 500VAC/min

IMAGE



OUTLINE

Dimensions	120*120*38mm
------------	--------------

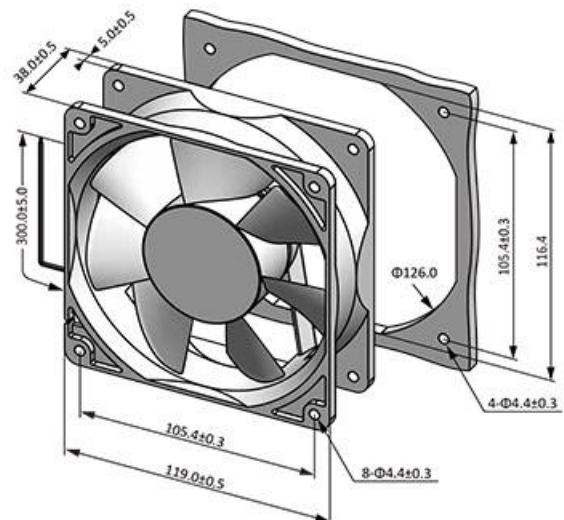

All specifications are correct at time of creation. All specifications and operation conditions contained in this datasheet are subject to change or improvement without prior notice to the user. This data is for evaluation purposes only. No guarantee is intended or implied by this data. For clarification and updated information, please contact us.