

受控文件

外发文件

外发编号 ERB-WK-20250822-004

TECHNICAL SPECIFICATION

Lithium-Thionyl Chloride Battery

Model: F0040-LF(EF651625/4P)

Approved	Checked	Draft
Hong Hu	/	Zhuolun Liu

Customer signature
Company name: Approved by: Signature date:

1. Scope

The document applies to F0040-LF(EF651625/4P) battery supplied by EVE Energy Co., Ltd. Specify quality, test method, performance, quality assurance and matters need attention etc..

2. Battery type

Lithium Thionyl Chloride

3. General characteristics

No.	Item	Characteristic	Remarks
3.1	Type	F0040-LF(EF651625/4P)	Bobbin type battery
3.2	Nominal Voltage	3.6V	Tested with 36K Ω /0.1mA load at +20 $^{\circ}$ C
3.3	Nominal capacity	0.75Ah	
3.4	Operating temperature	-55 $^{\circ}$ C~+85 $^{\circ}$ C	Operation under higher temperature than ambient temperature may lead to reduced capacity and lower voltage reading at the beginning of pulses. If continuous high temperature over +40 $^{\circ}$ C or low temperature down to -20 $^{\circ}$ C usage conditions, please consult EVE.
3.5	Outside dimensions		Please ref. to the production drawing
3.6	Nominal weight	About 8g	
3.7	Volume of battery	About 4.3cm ³	

4. Appearance and structure

4.1 Appearance

When checking the F0040-LF(EF651625/4P)cell appearance by eye, no scratch, swelling, deformation, corrosion, electrolyte leakage and other defects.

4.2 Structure

F0040-LF(EF651625/4P) is "bobbin design" cell, which cathode is cylindrical in shape.

Hermetic is ensured by a glass-to-metal sealing technology. (under a standard helium pressure, leakage rate $\leq 10^{-8}$ Pa·m³/sec).

5. Typical electrical performances

Item	Test condition	Initial Values*	Typical values after store for one year at $\leq 30^{\circ}\text{C}$ **
5.1 Open Circuit Voltage			
Room temperature	$20\pm 5^{\circ}\text{C}$	3.63~3.70V	3.63~3.73V
Low temperature	$-40\pm 2^{\circ}\text{C}$	3.63~3.70V	3.62~3.72V
High temperature	$60\pm 2^{\circ}\text{C}$	3.63~3.74V	3.64~3.74V
5.2 Load voltage 10mA(330Ω) discharge 6s			
Room temperature	$20\pm 5^{\circ}\text{C}$	3.20V	3.10V
5.3 Operation voltage discharge with 1mA load(3.6kΩ)			
Room temperature	$20\pm 5^{\circ}\text{C}$	Min.: 3.45V	Min.: 3.40V
Low temperature	$-40\pm 2^{\circ}\text{C}$	Min.: 3.00V	Min.: 2.80V
High temperature	$60\pm 2^{\circ}\text{C}$	Min.: 3.50V	Min.: 3.45V
5.4 Service life Cut off voltage is 2.0V Orientation: cathode up-right			
Room temperature: $20\pm 5^{\circ}\text{C}$	Loading: 3.6k Ω /1mA	Min.:720h	Min.:700h
Room temperature	Loading:660 Ω	Min.:85h	Min.: 80h
5.5 Electrolyte Leakage test	Above 1-4 item's testing: No leakage		
5.6 Deformation	Above 1-4 item's testing: The cell size don't exceed attached drawing's dimension.		

Note: *:Test data within 1 month according to the date code on shrink tube.

** :Test data within 1~12 months according to the data code on shrink tub.

6. Safety and environmental performance

6.1 Environmental test

6.1.1 Temperature cycling test

According to the UL* test requirement, the batteries are to be placed in a test chamber and subjected to the following cycles: raising the chamber temperature from $20\pm 3^{\circ}\text{C}$ to $70\pm 3^{\circ}\text{C}$ within 30min, and maintaining for 4h, then reducing the chamber temperature to $20\pm 3^{\circ}\text{C}$ and maintaining for 2h, then reducing to $-40\pm 3^{\circ}\text{C}$ and keep it for 4h, at last, raising to $20\pm 3^{\circ}\text{C}$ within 30min. Repeating the sequence for a further 10 cycles.

Pass/Fail criteria: the samples shall not explode or catch fire. In addition, the samples shall no leakage.

6.1.2 Low pressure (Altitude Simulation) test

According to the UL* test requirement, sample batteries are to be stored for 6h at an absolute pressure of 11.6KPa(1.68psi) and a temperature of $20\pm 3^{\circ}\text{C}$ ($68\pm 5^{\circ}\text{F}$)

Pass/Fail criteria: The batteries shall be no explosion or catch fire as a result of the altitude simulation test. In addition the samples shall be no vent or leakage.

6.1.3 Free fall test

According to the IEC** test requirement, each cell should be dropped 2 times from 1m height onto cement ground (total 6 times).

Pass/Fail criteria: The battery samples shall be no explosion or catch fire. In addition, the samples shall no vent or leakage.

6.1.4Vibration test

According to the UL* test requirement, a battery vibration frequency is to be varied at the rate of 1 hertz per minute between 10 and 55 hertz, and return in not less than 90 or more than 100 minutes. The battery is to be tested in three mutually perpendicular directions

Pass/Fail criteria: The battery samples shall be no explosion or catch fire. In addition, the samples shall no vent or leakage.

Warning: The description of the following abuse tests is for demonstration purposes only. During handling and application of lithium batteries, abusive conditions must be avoided. Any application or test requiring performance beyond the limits given hereby must be approved by EVE.

6.2 Safety test

6.2.1Heating test

According to the UL* test requirement, a battery is to be heated in a gravity convection or circulating air oven. The temperature of the oven is to be raised at a rate of $5\pm 2^{\circ}\text{C}$ per minute to a temperature of $130\pm 2^{\circ}\text{C}$ and remain for 10 minutes at that temperature before the test is discontinued.

Pass/Fail criteria: The battery samples shall be no explosion or catch fire.

6.2.2 Impact test

According to the UL* test requirement, a test sample cell was placed on a flat surface. A 5/8 in. (15.8 mm) diameter steel bar was placed across the center of the sample. The length of the bar should be at least as long as the width of the sample. A 20 pound (9.1 kg) weight was dropped from a height of 24 ± 1 in. (610 ± 25 mm)

on to the sample.

Pass/Fail criteria: The samples shall not explode or catch fire.

6.2.3 Crush test

According to the UL* test requirement, a cell was crushed between two flat hard surfaces (i.e. steel). The crushing was continued until a force of 3000 pounds (13kN±0.78kN) was applied. The speed of the crush was documented for information purposes. Once the maximum pressure was obtained, it was released.

Pass/Fail criteria: The battery samples shall be no explosion or catch fire.

6.2.4 External Short-circuit test

According to the UL* test requirement, each test sample, in turn, was short-circuited by connecting the positive and negative terminals of the sample with a circuit load having a maximum resistance $< 0.1\text{ohm}$. The sample was discharged until a fire or explosion was obtained, or until it had reached a completely discharged state of less than 0.2 volts and the cell case temperature had returned to $+10^{\circ}\text{C}$ ($+18^{\circ}\text{F}$) of ambient temperature.

Pass/Fail criteria: The battery samples shall be no explosion or catch fire.

6.2.5 Abnormal charging test

According to the UL* test requirement, each test sample battery is to be subjected to a charging current of three times the current I_c , specified by the manufacturer by connecting it in opposition to a dc-power supply. The specified charging current is to be obtained by connecting a resistor of the specified size and rating in series with the battery.

The test charging time is to be calculated using the formula:

$$T_c = 2.5 * C / (3 * I_c)$$

In which

T_c —charge time, hour, $T_c \geq 7\text{Hour}$;

C —Nominal capacity, Ah;

I_c —Max. charging current, mA. F0040-LF(EF651625/4P) maximum charge current is 0.010A.

Pass/Fail criteria: The samples shall be no explosion or catch fire.

6.2.6 Forced-discharge test

According to the UL* test requirement, a completely discharged cell is to be force-discharged by connecting it in series with fully charged cells of the same kind. The number of fully charged cells to be connected in series with the discharged cell is to equal the maximum number less one of the cells to be covered for series use, the

circuit load resistance less than 0.1Ω . The sample is to discharge until a fire or explosion is obtained, or until it has reached a completely discharge state of less than 0.2V and battery case temperature has returned to $\pm 10^{\circ}\text{C}$ ($+18^{\circ}\text{F}$) of ambient temperature.

Pass/Fail criteria: The samples shall be no explosion or catch fire.

References to safety standards

**UL Underwriters Laboratories "Standard Lithium Battery"—UL1642—Sixth Edition—2020.*

***IEC International Electro technical Commission International safety standards for lithium batteries “IEC 60086-4” –Fourth Edition – 2019*

Note: This specification use the latest release version of the standard documents above as the criterion

7. Product mark

7.1 Battery’s label specification

- ① type ② nominal voltage ③ positive and negative electrode mark
- ④ date code ⑤ safety warning

7.2 Date code:

Date code will be marked on the sleeve of battery.

Method: MM YYYY, “MM” stand for: month; “YYYY” stand for: year.

8. Incoming inspection

Before shipping, EVE will 100% check open circuit voltage of the battery (OCV) and the load voltage. Also EVE will sampling tests the battery capacity, visual appearance and size.

As for the customer's incoming inspection, EVE recommended sampling according to GB2828.1-2003, GB2829-2002 standard.

Table 1 Acceptability quality level

No	Item	Technical request	Check level	AQL
1	Dimension	2-6	S-2	0.65
2	Appearance	2-8	II	1.0
3	Open circuit voltage	3-1	II	0.4

Table 2 Sampling amount

Lot size /pcs	sampling amount /pcs
≤3200	32
3200~10 000	50
>10 000	80

9. Storage

Lithium batteries should be stored in a cool, clean, dry environment, the recommended temperature is $\leq +30^{\circ}\text{C}$, relative humidity $\leq 60\%$, should avoid contact with corrosive materials, away from fire and heat.

10. Safety

10.1 We propose to use lithium cell process, need to comply with the following provisions:

- Before use, do not remove the battery from the original packaging.
- Do not scattered placed the battery together in order to avoid accidental short circuit.
- Do not heat the battery above 100°C or incinerated.
- Do not recharge the battery.
- Do not weld or solder directly to battery, should use the battery with terminals or wires.
- Do not mix the new and used batteries or different brand battery.
- Do not disassembly or open battery
- Do not short circuit the battery or reversely contact the positive and negative terminals.

EVE Battery verified by Underwriters Laboratory as "engineers replace batteries."

10.2 Backups circuit design prevent charging battery

The following diagram shows by the Underwriters Laboratory recommended the protection of memory backup circuit reverse charging circuit, shown in Figure 10-1. If the resistance R is diode replaced by Figure 10-2 is also available. Set such a safety device in the circuit board is absolutely necessary, which includes a backup battery and power supply in parallel. Safety devices should be as close as possible the battery. Otherwise, do not intend to short circuit in the adjacent PCB or bad solder joints, may bypass the safety device, so that the power supply through the reverse (charging) current through the battery.

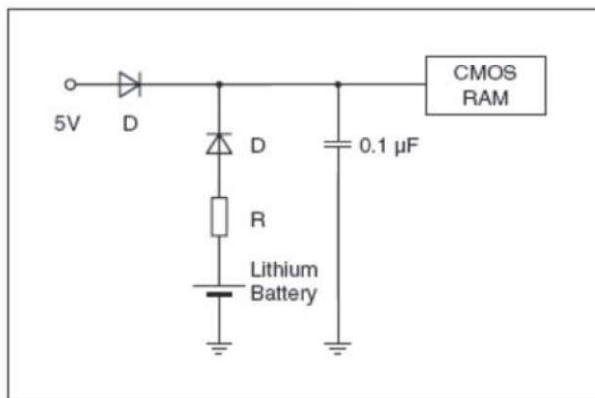

FIG. 10-1

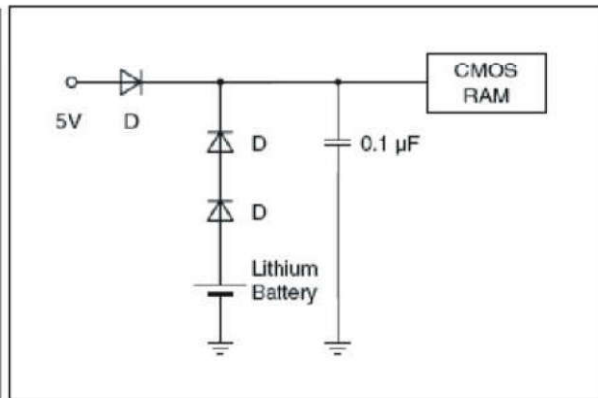

FIG. 10-2

10.3 Incorrect and not recommend installation

Fig.10-3~5 are typical examples of contacting the positive and negative terminals reversely. Installing the batteries as shown will charge the reversed battery, and the battery will continue to heat up, causing safety hazards. Fig.10-6 is a typical battery installation error. The cathode must be upright when the battery is installed. Because the discharge performance is inconsistent with the upright and inverted battery, If the battery installation direction is not uniform in the vertical direction, it will reduce the battery life and even cause safety risks. It is not recommended to connect diodes in series between ER and SPC (Fig.10-7). It may reduce the working voltage of the battery pack and cause abnormal operation of the device. Please consult EVE for details.

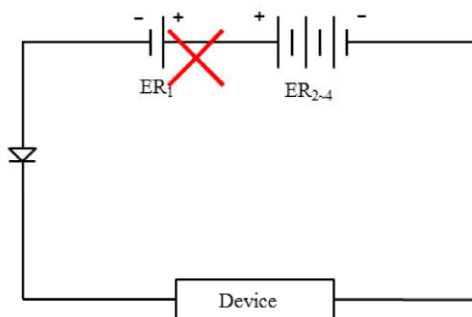

FIG. 10-3

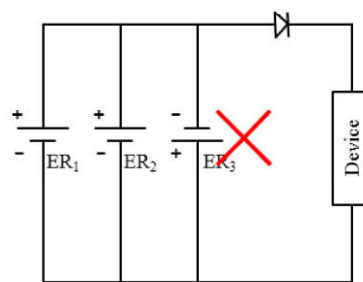

FIG. 10-4

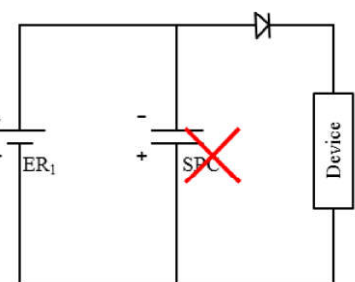

FIG. 10-5

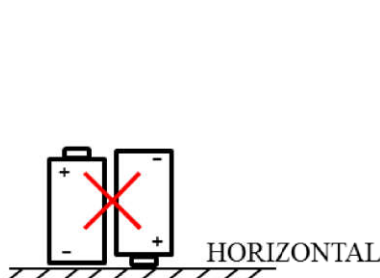

FIG. 10-6

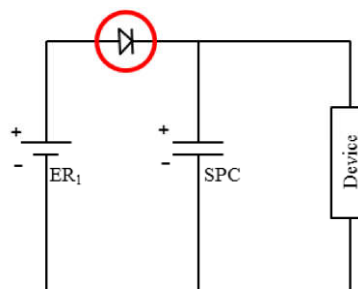

FIG. 10-7

11. Transportation

F0040-LF(EF651625/4P) battery has been proven to meet the tests and Criteria requirements of UN Manual, Part III, subsection 38.3 (Document No.: ST/SG/AC.10/11/Rev 5-2011). According to U.N. "Recommendations on the Transport of Dangerous Goods Model Regulations" (Document No.: ST/SG/AC.10/1- Rev 16 (Vol. I) -2009), The F0040-LF(EF651625/4P) battery's lithium content is not more than 1g, So F0040-LF(EF651625/4P) battery can transport as non-restricted goods.

12. Modification of this specification

Modification must be carried out after the prior mutual agreement. All accident or issues caused by any events that are neither defined nor described in this specification, mutual discussion shall take place for the resolution.

13. Important notes

- 1) The batteries are warranted to conform to the description contained in this specification for a period of twelve [12] months from the ex-factory date without use (after 6 months storage, EVE recommend to active the battery, more details please consult EVE), any claim by customer (apparatus manufacturer or distributor) must be pointed out within such period. During that warranty period, if the batteries are proved to become defective under proper stored and handled, EVE will replace the batteries for free.
- 2) Customers are responsible to confirm and assure the matching and reliability of batteries under actual application.
- 3) EVE shall not warrant or be responsible in any case where customers fail to carry out proper handling, operating, installation, testing and maintaining batteries, or don't follow the instruction, cautions, warnings, notes provided in this specification and other EVE's reasonable instructions or advises.
- 4) This product specification will be validated assuming that it is accepted when it is not returned within six months from the date of issue.

14. Remark of production duty

Customers must strictly operate according to specification and advises of EVE ENERGY CO., LTD.

Operation at temperature different from ambient may lead to reduced capacity and lower voltage reading at the beginning of pulses. EVE will be exemption from liability if the batteries are improper used or abused and then cause fire, explosion, the human body or property damage.

15. Drawing (unit of size: mm)

