

PV-ezRack®

By Clenergy 

PostMount 1-A with ECO Rail

Code-Compliant Planning and Installation Guide V2.1

Complying with AS/NZS1170.2: 2011 ADMT 4-2016



1. Introduction

Clenergy PV-ezRack PostMount 1-A is a ground mounting system suitable for large scale commercial and utility scale installations. PV-ezRack PostMount 1-A has been developed to fit any PV module in the outdoors and uneven ground areas. PV-ezRack PostMount 1-A have good compatibility for the different region via the angle adjustment (10°~60°). Using high quality engineered components PostMount 1-A saves developers and installers, time and money when delivering large scale projects.

Please review this manual thoroughly before installing PostMount 1-A. This manual provides the following contents:

- (1) Installation planning;
- (2) Installation instructions.

List of Contents

Product Introduction	01
Tools & Components	02
System Overview	03
Installation Instruction	06
Certification Letter	08
Warranty	09

The PV-ezRack PostMount 1-A parts, when installed in accordance with this guide, will be structurally adequate and meet the AS/NZS1170.2:2011 Admt 4-2016 standard. During installation, and especially when working on the ground, please comply with the appropriate occupational health and safety regulations. Please also pay attention to other relevant regulations in your local region. Please check that you are using the latest version of the installation manual by contacting Clenergy via email on www.clenergy.com.cn or contacting your local distributor.

The installer is solely responsible for:

- Complying with all applicable local or national building codes, including any updates that may supersede this manual;
- Ensuring that PV-ezRack and other products are appropriate for the particular installation and the installation environment;
- Using only PV-ezRack parts and installer supplied parts as specified by PV-ezRack project plan (substitution of parts may void the warranty and invalidate the letter of certification);
- Recycling according to the local relative statute;
- Ensuring that there are no less than two professionals working on panel installation;
- Ensuring the installation of related electrical equipment is performed by licenced electricians;
- Ensuring safe installation of all electrical aspects of the PV array, including providing adequate earth bonding of the PV array and PV-ezRack® PostMount components as required in AS/NZS 5033-2014 ADMT 2 2-2018.

Tools & Components

2. Tools & Components

2.1 Tools

Tools



Allen Key 6 mm



Spanner



Torque Wrench



5m Tape

2.2 Components

Components

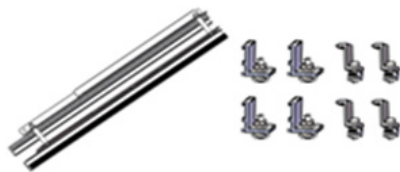

PM1-A Components Packx1



Pole for PostMount 1-A
83x2400mmx1

System Overview

3. System Overview

3.1 Overview of PV-ezRack PostMount 1-A

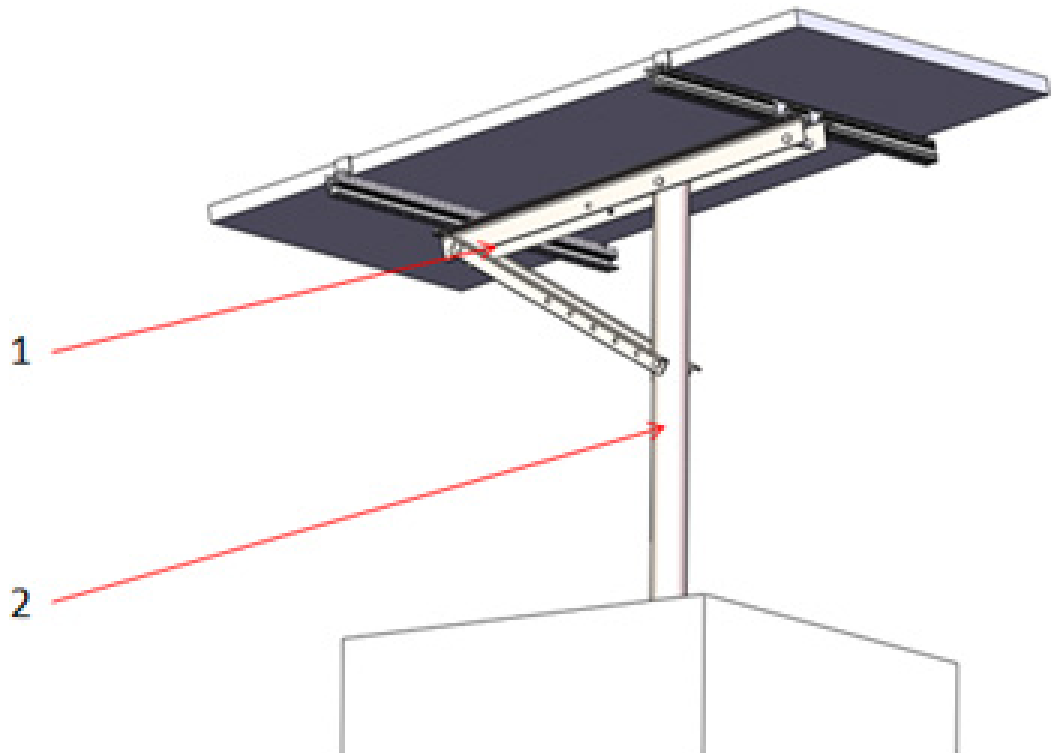

- ① PM1-A Components Pack
- ② PM1-A Pole, Ø83x2400mm

Side view drawing of PV-ezRack PostMount 1-A is shown below. The panels tilt angle and embedment depth below are for reference only. Please refer to Certificate Letter to obtain the certified max panels tilt angle and min embedment depth for different wind regions and different soil types.

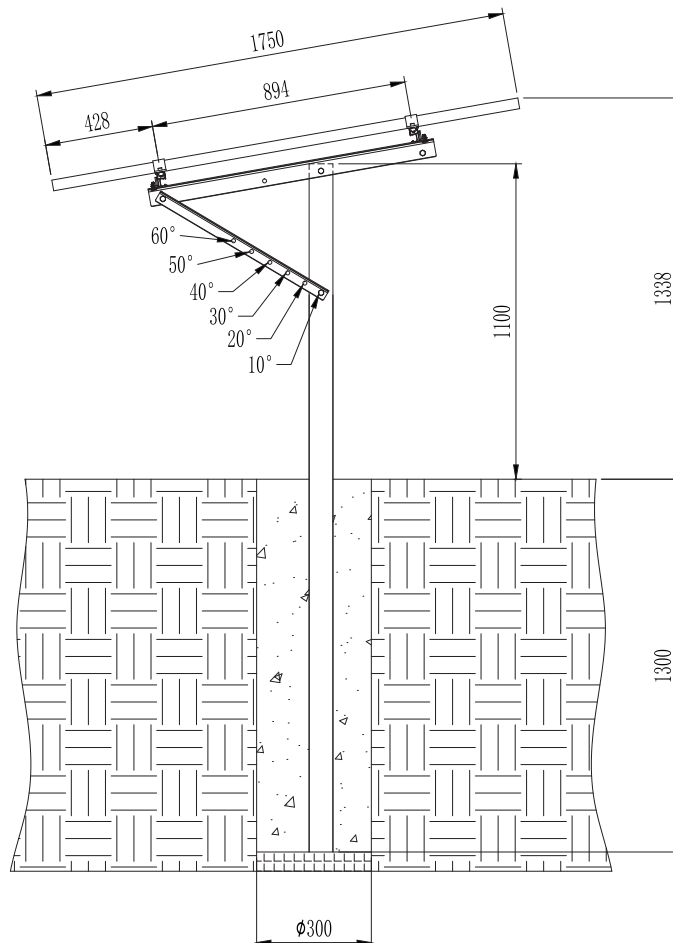

3.2 Precautionary Measures for Stainless-Steel Fastener Installation

Improper operation may lead to the deadlock of bolts and nuts. Follow the steps below to reduce this risk.

3.2.1 Reduce the friction coefficient

- (1) Ensure that the thread surface is clean (no dirt or contaminant).
- (2) Apply lubricant (grease or 40# engine oil) to fasteners prior to tightening to avoid galling or seizing in the threads.

3.2.2 General installation instructions

- (1) Apply force to fasteners in the direction of thread.
- (2) Apply force uniformly to maintain required torque.
- (3) Professional tools and tool belts are recommended.
- (4) Avoid using electric tools for final tightening.
- (5) Avoid working at high temperatures.

3.2.3 Safe Torques

Please refer to safe torques defined in this guide as shown in the figure below. If power tools are required, Clenergy recommends the use of low speed only. High speed and impact drivers increase the risk of bolt galling (deadlock). If deadlock occurs and you need to cut fasteners, please make sure that there is no load on the fastener before you cut it. Avoid damaging the anodized or galvanized surfaces.

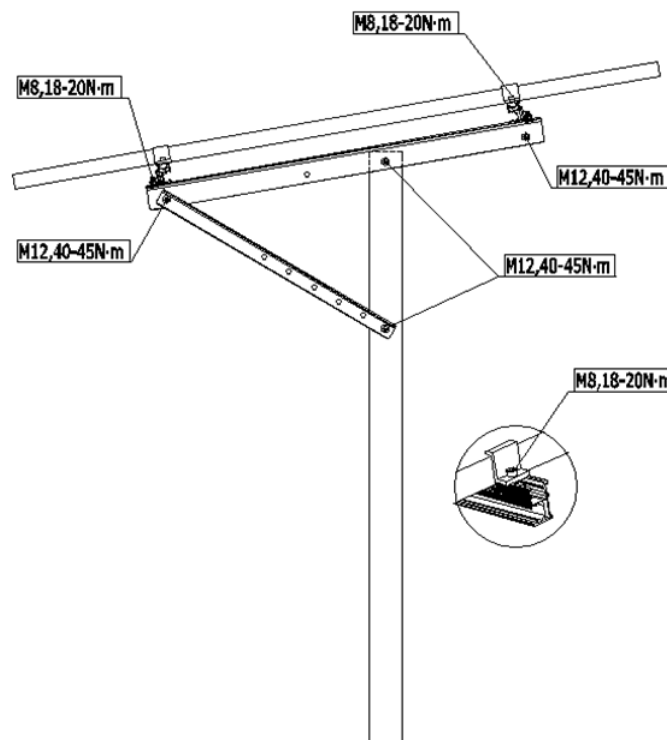

3.3 Installation Dimensions

All drawings and dimensions in this installation guide are for generic reference. The PV-ezRack PostMount 1-A is to be optimized to suit specific conditions for each project and documented in engineering drawings. As a result, major components of the PV-ezRack PostMount 1-A may be provided in sectional sizes and lengths that vary from those shown in this guide. The installation operations detailed in this instruction guide remain the same regardless of the component size. In case you need to do any on-site modifications or alteration of the system in a way that would be different from engineering drawings, please provide marked up drawings/sketches for Clenergy's review prior to modification for comment and approval.

4. Installation Instruction

4.1 Pole 83*2400 Installation

Dig a hole to the diameter 300-400mm and depth 1200-1400mm highlighted in the PM1-A engineering letter. Cover the bottom of the hole with 50-70mm gravel.

Place the pole into the middle of the hole and fill it with concrete. Maintain the position of the post. The allowed vertical tolerance is $\pm 2^\circ$. Keep the axle of the 2- $\varnothing 14$ holes parallel to East-West; keep the vertical angle deviation within $\pm 5^\circ$. For more than one system on one site maintain all the axles of 2- $\varnothing 14$ holes aligned.

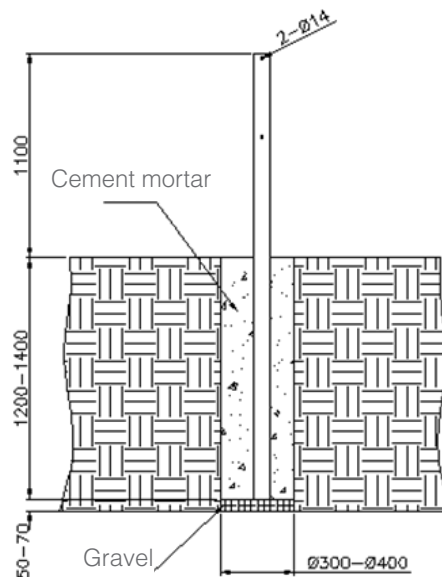

4.2 PostMount 1-A Kit Installation

4.2.1 As show in figure on the right, with M12 * 120 hex bolts and nuts to lock Angle Steel 63*40*1010 on the Pole. And then use M12 * 120 hex bolts and nuts to lock supporting rod 40 * 40 * 682 on the Pole.

Note: supporting rod around multiple holes which can be adjusted by adjusting the mounting, adjustable angle of 10 °, 20 °, 30 °, 40 °, 50 ° and 60 °.

Recommended torque for M12 bolts is 40~45 N·m

4.2.2 As show in figure on the right, place the ECO Rail on Angle Steel. Use the Cross Connection Clamp, Cup head square neck bolts M8*25, Hexagon nut with flange M8 to lock on the Angle Steel 63 * 40 * 1010.

Recommended torque for M8 bolts is 18~20 N·m

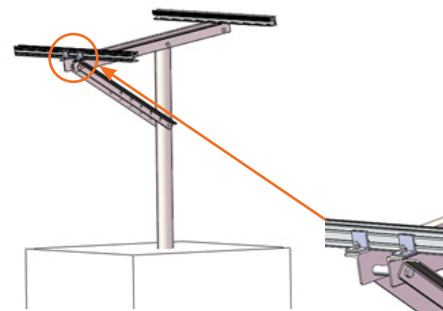

Installation Instruction

4.2.3 Position the PV Panel landscape by aligning the centre line with the ECO Rail. And fix the PV Panel to the Rails by using End Clamps.

Recommended torque for M8 bolts is 18~20 N·m

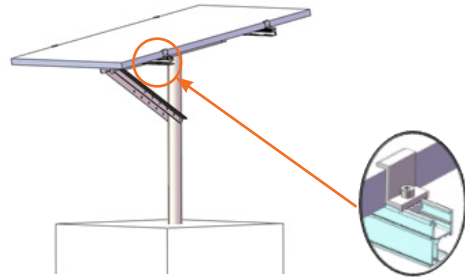

Certification Letter

Our Ref: 8762-PM1A/AA
31 August 2020

CLENERGY AUSTRALIA
1/10 Duerdin St
Clayton VIC 3168

Array Frame Engineering Certificate

RE: Postmount PM1-A Installation – PV panel 1750mmx1010mm

Gamcorp (Melbourne) Pty Ltd, being Structural Engineers within the meaning of Australian Regulations, have carried out a structural design check of the PV-ezRack Postmount PM1-A for installation in four general soil types within Australia and New Zealand. The design check has been based on the drawings of the system and its components, and other documents and information, provided by CLENERGY AUSTRALIA.

Part No.	Part Name	Description
13-11011-004	ER-EC-ST	PV-ezRack Standard End clamps
	ER-R-ECO	PV-ezRack ECO Rail 1100mm
13-16041-001		Left and right supporting beam, angle steel 63*40*1010
13-16041-002		Left and right supporting rod, angle steel 40*40*682
13-15010-054	ER-P-83/2400	PV-ezRack, Pipe \varnothing 83*2400mm (PM1-A)

We find the Postmount PM1-A to be structurally sufficient for the proposed installation, based on the following conditions:

- Wind Loads according to AS/NZ1170.2:2011 (R2016):
 - Wind Terrain Category 2;
 - Wind average recurrence interval of 100 years for ultimate state and 25 years for serviceability;
 - Wind region A, B, C & D;
 - $M_d=1$, $M_s=1$ & $M_t=1$;
- Max. Solar Panel length 1750mmx1010mm;
- Steel members to be **Q235B**;
- Aluminium members to be **AL6005-T5**;
- Bolts to be **SUS304**;
- The certification **excludes** assessment of PV panels
- Refer to **Table 1** for maximum tilt angle and footing options;
- Dimensions as shown here on the picture;

Gamcorp (Melbourne) Pty Ltd A.C.N 141 076 904 A.B.N 73 015 060 240
www.gamcorp.com.au melbourne@gamcorp.com.au
 Suite 4, 346 Ferntree Gully Rd, Notting Hill VIC 3168 Tel: 03 9543 2211

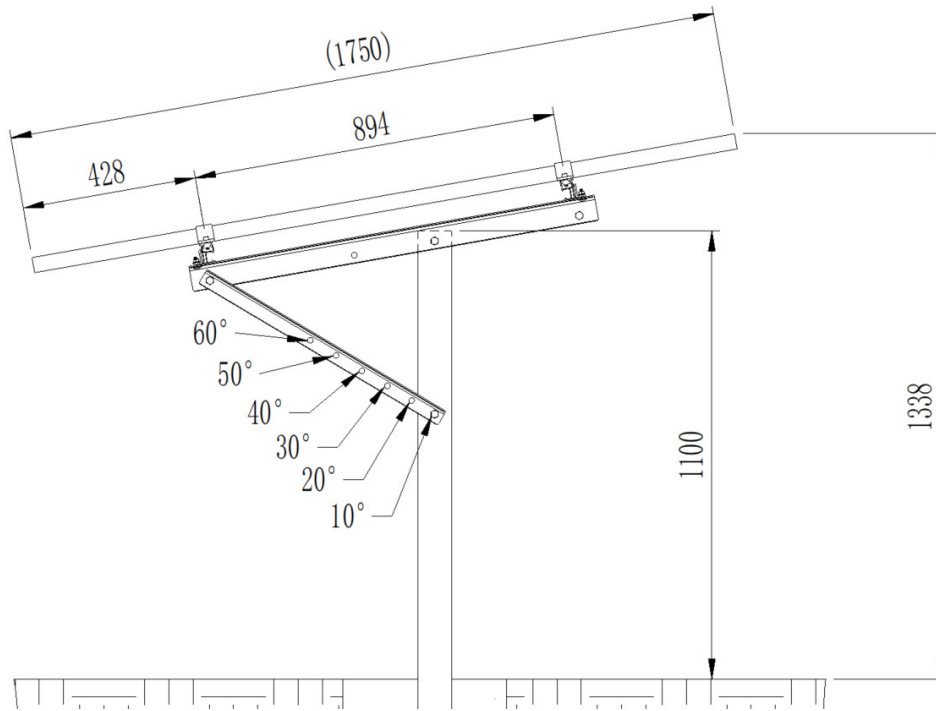

Table 1 – Maximum Tilt Angle and Footing Options

	Wind Region			
	Region A	Region B	Region C	Region D
Wind speed (m/s)	41	48	59	73
Maximum tilt angle (°)	60	60	50	20
Soil Type	Post embedded in concrete pier: 300 mm diameter concrete piers minimum depth (m)			
<u>Hard class soil</u> [Gravels; dry (hard) clays]	0.80	0.90	1.00	0.80
<u>Very Firm class soil</u> [Dry (stiff) clays; clayey sands; coarse sands; compact sands]	0.85	0.95	1.10	0.85
<u>Firm class soil</u> [Damp clays; sandy clays; damp sands]	0.95	1.05	1.20	0.95
<u>Soft class soil</u> [Wet clays; silty loams; wet or loose sands]	1.15	1.25	1.40	1.15

ISO 9001:2008 Registered Firm
 Certificate No: AU1222

Gamcorp (Melbourne) Pty Ltd A.C.N 141 076 904 A.B.N 73 015 060 240
www.gamcorp.com.au melbourne@gamcorp.com.au
Suite 4, 346 Ferntree Gully Rd, Notting Hill VIC 3168 Tel: 03 9543 2211

Notes:

- 1. This certification is applicable for the Postmount PM1-A with dimensions as shown in this letter.**
- 2. Other piers dimensions are possible, contact Gamcorp, if required.**
- 3. Panel weight calculated: 20kg.**
- 4. Embedment depth is relevant for soils, having adhesion capacity from 300mm of the ground level; in other cases contact Gamcorp.**
- 5. For concrete piers foundation, use 25 MPa strength concrete (minimum). It is recommended to insert N12 bar 200mm long at the bottom of the post into the concrete piers.**
- 6. If any of the above conditions cannot be met, the structural engineer must be notified immediately.**

Construction is to be carried out strictly in accordance with the manufacturers instructions and site soil report recommendations. This work was designed by **Ali Askari** in accordance with the provisions of relevant Regulations and in accordance with sound, widely accepted engineering principles.

Yours faithfully,
Gamcorp (Melbourne) Pty Ltd



L. van Spaandonk
Principal Engineer
FIEAust Cpeng NER

10 Year Product Warranty



As the manufacturer of quality solar mounting systems, Clenergy Australia provides a warranty for all PV-ezRack products it supplies in Australia and New Zealand ("Products"). The warranty provided by Clenergy Australia is subject to the conditions contained in this document ("Warranty"). No other warranty provision implied or otherwise is to be assumed. Your Warranty coverage is in accordance with this document.

Product Warranty Table for Installations in Corrosivity Category 1, 2, 3, 4 and 5 (ISO 9223)

# Product	Material	Standard or Customized Product	Product Warranty			
			Corrosivity Category 1, 2 and 3	Corrosivity Category 4	Corrosivity Category 5	
1	Aluminium Components	6005CL-T5 mill finish	Standard	10 years	10 years*	10 years*
		6005-T5 anodized to 10 microns	Standard	10 years	10 years*	10 years*
		6005-T5 anodized to 15 microns	Customized	10 years	10 years	10 years*
		6005-T5 anodized to 20 microns	Customized	10 years	10 years	10 years
2	Galvanized Steel Components	Galvanized Steel at 85 microns in average	Standard	10 years	10 years	Not warranted
3	Stainless Steel Components	SUS304	Standard	10 years	10 years	10 years
4	Fasteners (bolts/nuts/washers)	SUS304	Standard	10 years	10 years	10 years
		SUS316	Customized	10 years	10 years	10 years
5	Buildex Screws for Tile Interface	Carbon Steel SAE 1022 with Climaseal 3 Finish	Standard	10 years	10 years**	10 years**
6	Buildex Screws for Tin Interface	Carbon Steel SAE 1022 with Climaseal 3 Finish	Standard	10 years	Not warranted	

* Subject to interface spacing reduction as advised by Clenergy Australia. Please contact us for more details.

**The screws under tile interface are assumed to be installed a category 1, 2 or 3 micro-climate within the roof structure.

Warranty Scope:

Your solar mounting Product has been manufactured to high standards, however, should any manufacturing defect arise, please contact Clenergy Australia. We will arrange for an inspection of the affected Product(s) to determine the extent of the problem.

Details are provided below as to the extent of your Warranty coverage and any exclusions that may apply. Please read these provisions carefully to ensure you receive the appropriate assistance and support in a timely manner. Please also contact Clenergy Australia if any part of this Warranty is unclear, or you wish to discuss your rights and remedies under this Warranty.

If your Product fails during the Warranty periods set out in the Warranty table above due to a defect in:

- (a) materials and/or workmanship on and from the date of the Product's delivery; or
- (b) structural integrity on and from the date of the Product's installation,

Clenergy Australia will at its election either repair or resupply the defective Product provided that:

- The Product was installed correctly by a Clean Energy Council ("CEC") accredited or equivalent accreditation installer, following the Clenergy installation manual provided at time of purchase.
- The Product has been maintained correctly in accordance with section "Care of your Product" below.

Warranty Conditions:

- Any and all costs for repair or replacement outside the Warranty period are the responsibility of the customer.
- Where Clenergy attends a site and finds that the Product is not faulty, the costs for the visit will be payable by the customer.
- Defective Products shall be uninstalled and/or reinstalled at the customer's expense and risk.
- Under certain conditions, the Warranty can be extended to more than 10 years at an extra cost, available upon request.

Warranty Exclusions:

- Product finish (natural surface oxidation) or any natural impairment or surface corrosion that does not compromise the structural integrity.
- Products sold or installed outside of Australia and New Zealand unless approved previously in writing by Clenergy Australia.
- Damage caused by transport, mishandling, incorrect storage, improper loading or willful conduct.
- Any Product not correctly installed in accordance with our installation manual, or any specific design instruction or special conditions as advised by Clenergy Australia.
- Damage caused by the Product being modified in any way unless previously agreed to in writing by Clenergy Australia.
- The use of the Product for purposes other than the mounting of PV solar panels.
- Installations where the environment is excluded in the "Products Warranty Table" above, and for galvanized steel ground system Products, where the pH level is outside the range of 6-8, unless agreed to in writing by Clenergy Australia prior to installation.

- Damage caused by extreme weather conditions or any other natural or man-made event outside of our control.
- Damage caused by attachments not designed or approved for connection to the Product.
- Damage caused by lightning strikes or excessive currents through the earthing/grounding clamps, clips or lugs.

Our Products may come with guarantees that cannot be excluded under the Australian Consumer Law. You may be entitled under statute to a replacement or refund for a major defect in the Products. You may also be entitled under statute to have the products repaired for any defect which does not amount to a major defect. The benefits given by this Warranty are in addition to any statutory rights and remedies you may have under Australian law.

Product Care:

Clenergy Products are designed to be durable with minimal care, however it is important that you maintain your mounting Product in accordance with proper practices. This includes regular maintenance and inspection to avoid damage.

The aluminum components are made from either AL 6005CL-T5 or AL6005-T5 and may also have a clear anodization. The aluminum may undergo some surface oxidization in service. Please note that this is normal and part of the natural ageing process. The result may even be beneficial to the longevity of the Product, as the oxidization can provide additional protection against degradation by pollution and atmospheric corrosion.

- The torque values of fastener connections on mounting system must be checked annually and corrected if needed in accordance with Clenergy Australia's installation manual.
- Regular cleaning to remove any soil or other possible contaminants must also be performed. Cleaning should be performed in accordance with guidelines recommended by the Galvanizers Association of Australia (GAA) (for Products supplied in Australia) or the Galvanizers Association of New Zealand (GANZ) (for Products supplied in New Zealand) or any other similar organisations (as applicable). When using tin interfaces for installation works, screws not exposed to frequent rain should be washed down with fresh water at least every 6 months.
- You should not use harsh chemicals or highly abrasive materials that may damage Product surfaces. Use only cleaners that are designed for aluminium and always wash them off with clean water afterwards. Steel components should be inspected before and after installation and any damage to the galvanizing should be treated immediately to prevent rusting. It is normal for galvanized Products to develop a surface barrier (the 'patina'), which helps to protect the surface from contaminants in the atmosphere and does not adversely affect the Product.
- You should also ensure that if the Product is stored prior to installing that it is not contaminated by contact with rusty items or other impurities such as dirt and chemicals. Should this occur, you must clean the Product and make any repairs using approved methods such as galvanized paint and antirust treatments immediately before installation.



Innovating renewable energy

Clenergy Australia

1/10 Duerdin Street, Clayton VIC 3168 Australia
 Tel: +61 3 9239 8088 Fax: +61 3 9239 8024
 E-mail: sales@clenergy.com.au
www.clenergy.com.au

Clenergy China

999-1009 Min'an Rd, Huoju Hi-tech Ind. Dev. Zone
 Xiang'an District 361101, Xiamen, Fujian, China
 Tel: +86 592 311 0088 Fax: +86 592 599 5028
 E-mail: sales@clenergy.com.cn
www.clenergy.com.cn

Clenergy EMEA

Esplanade 41, 20354 Hamburg, Germany
 Tel: +49 (0) 40 3562 389 00
 E-mail: sales.emea@clenergy.com

Clenergy Japan

Nittochi Yamashita Building 5th Floor
 23 Yamashita-cho, Yokohama, 231-0023 Japan
 Tel: +81 45 228 8226 Fax: +81 45 228 8316
 E-mail: sales@clenergy.co.jp
www.clenergy.jp

Clenergy Philippines

145 Yakal St., San Antonio village, Makati City, Philippines
 Tel: +63 977 8407240
 E-mail: sales_ph@clenergy.com
www.clenergy.ph

Clenergy Thailand

9/2, 5th Floor, Vorasin Building, Soi Yasob 2, Viphavadee-Rungsit
 Road, Chomphon Sub-district, Chatuchak District, Bangkok 10900
 Tel: +66 (0) 2 277 5201, +66 (0) 6 3228-0200
 E-mail: sales_th@clenergy.com, support_th@clenergy.com
www.clenergythailand.com

Clenergy Singapore

24 Raffles Place #28-01 Clifford Centre Singapore 048621
 Tel: +65 9743 1425
 E-mail: vincent.chan@clenergy.com

Clenergy Malaysia

Tel: +86 18750231005
 E-mail: sales_em@clenergy.com

Clenergy Vietnam

Tel: +86 592 3110095
 E-mail: sales_vietnam@clenergy.com;
susie.chen@clenergy.com

Clenergy Korea

Tel: +8210-4684-8088
 E-mail: sales.kr@clenergy.com

Worldwide Network

