

VLRV
LFP Battery System

User Manual

V2.8

Revision Table

No	Version	Revised by	Content	Revision Date
1	Rev1.0		First release	2022.09.06
2	Rev2.0		Update	2023.07.24
3	Rev2.1		Update Format	2023.08.02
4	Rev2.2		Update Content	2024-03-05
5	Rev2.3		Update Format	2024-04-11
6	Rev2.4		Update Content	2024-11-30
7	Rev2.5		Update Bluetooth	2025-02-15
8	Rev2.6		Cable renewal	2025-07-31
9	Rev2.7		Update Content	2025-10-09
10	Rev2.8		Update Content	2026-04-24

Content

1 Overview	1
1.1 Scope of Application	1
1.2 Target Audience	1
1.3 User Manual	1
1.4 Disclaimers	1
2 Product Description	2
3 Safety Instructions	3
3.1 Label Description	3
3.2 Installation Tools	4
3.3 Attention Items	4
3.3.1 Manual Custody	4
3.3.2 Operator Requirements	4
3.3.3 Measuring Instrument	4
4 Product Description	5
4.1 Product Introduction	5
4.2 Module Illustration and Front Panel Description	6
4.2.1 VLRV1280 Appearance & Dimension Schematic Diagram	6
4.2.2 VLRV2560 Appearance & Dimension Schematic Diagram	7
4.2.3 VLRV5120 Appearance & Dimension Schematic Diagram	8
4.4 VLRV Series Battery Front Panel Diagram	9
4.5 LED Indicator status and definition	10
4.6 Communication Port Diagram and Description	11
5 Battery Installation	12
5.1 Handling, Transportation, Storage	12
5.1.1 Handling	12
5.1.2 Transportation	12
5.1.3 Storage	12
5.2 Battery Installation Requirement	13

5.2.1 Environment Requirement	13
5.2.2 Open-box Inspection.....	13
5.2.3 Precautions before Installation	14
5.3 Battery Installation.....	15
6 Battery Use.....	20
6.1 Bluetooth Setting	20
6.2 Heating Settings	23
6.3 Firmware Upgrade	24
6.3.1 Comm pcb Upgrade	24
6.3.2 BMS Upgrade	25
6.4 Bluetooth Rename	27
6.5 Battery status.....	28
6.6 Supplementary Power	29
6.7 Battery Discharge and End-of-life Assessment	29
6.7.1 Battery Discharge	29
6.7.2 Capacity Test.....	29
7 Maintenance.....	30
7.1 Common Faults (Phenomenon) and Solutions	30
7.2 Daily Maintenance.....	31
8 Cautions and Warranty	32
8.1 Cautions	32
8.2 Description of Warranty.....	32

1 Overview

1.1 Scope of Application

This document provides comprehensive information on Voltgo RV series LFP battery products, including their specifications, operational specifications, maintenance procedures and other relevant details. These LFP battery products, developed by Voltgo Power, are widely used in various scenarios, such as solar lighting, toy cars, medical carts, recreational vehicles (RVs), and E-boats.

1.2 Target Audience

This manual is intended for professionals and technical personnel who install, operate and maintain the batteries, as well as for end-users who may need to view relevant technical parameters. Any individual engaging in battery operations must be qualified for electrical work.

1.3 User Manual

Before the operation of the battery module, it is essential to undergo appropriate training and carefully read this manual to ensure a comprehensive understanding of the product. To avoid potential risks of short-circuits, please remove any metallic objects like jewelry, watches, pens, metal bars, and frames. After reading, please store this manual in a secure location for future reference.

1.4 Disclaimers

Failure to operate this product correctly may result in severe injury to oneself or others, as well as damage to the product or surrounding property. By using this product, you are deemed to have fully understood, acknowledged and accepted all the terms and contents in this document. Users assume responsibility for their actions and any resulting consequences. The company shall not be held liable for damages caused by the user's failure to comply with the provisions stated in this document or the user manual.

The content of this manual will be periodically updated and revised without prior notice. We recommend visiting our official website or contacting local distributors to obtain the latest version of the product manual.

2 Product Description

Lithium-ion batteries represent a new generation of green energy batteries. In recent years, the rapid development of lithium-ion battery technology has accelerated the replacement of traditional lead-acid batteries across various power fields. Voltgo Power develops and produces RV LFP battery products, which are suitable for low-voltage lead-acid replacement applications. These products adopt the highest safety performance lithium iron phosphate cells, with a high-precision battery management system (BMS). The BMS monitors and collects real-time data on voltage, current and temperature of each cell within the module. The BMS also has a passive balance function and advanced battery control strategy, further enhancing the performance of the battery pack.

The VLRV series battery products consist of LFP battery modules, BMS/BMU, housing, and wiring. Each module is equipped with comprehensive protection functions. The modules can be connected in parallel to meet the expansion needs.











The VLRV series battery products are designed with ABS shell, ensuring 24/7 usability and offering exceptional benefits such as waterproof, impact resistance, good insulation performance, easy installation, and maintenance-free operation. Some products also feature special functions such as Bluetooth and low-temperature heating, catering to the application needs of RVs, solar street lights, small medical equipment, toys, and other small energy storage applications.

3 Safety Instructions

3.1 Label Description









To ensure the user's personal safety when using this product, this manual provides relevant identification information and uses appropriate symbols to alert the user. It is recommended that the user carefully reads the following list of symbols used in this manual.

Table 3-1 Label description

	Potentially Low Risk: May result in mild or moderate impairment if not avoided.
	High Risk: May result in serious injury or death if not avoided.
	The battery terminals must be disconnected before commencing work on the battery.
	The battery could explode and/or be severely damaged if dropped or crushed.
	The battery may explode if exposed to open flames or other extreme sources of heat.
	This side should be facing up.
	Handle with care to avoid damage.
	Keep dry.
	Keep the battery out of reach of children.
	Do not short circuit.
	Do not reverse connection of the positive and negative terminals.

3.2 Installation Tools

Table 3-2 Installation tool sheet

Tools	Multi-meter 	Protective gloves 	Insulated anti-smashing shoes 
Installation Tools	Electric screwdriver 	Cross screwdriver 	Socket spanner 
	Slotted screwdriver 	Wire stripper 	

3.3 Attention Items

3.3.1 Manual Custody

This manual contains important information about the RV batteries. A careful reading of this manual will help you become familiar with this product. Please keep this manual in a safe place accessible to maintenance personnel whenever needed.

3.3.2 Operator Requirements

 Only trained and qualified professionals should perform various operations on the product. The operator should be fully familiar with the product's system components, operating principles, and the user manual.

3.3.3 Measuring Instrument

 To ensure that the electrical installation meets the requirements, please use relevant electrical measuring equipment, such as multi-meter or power meters.

4 Product Description

4.1 Product Introduction

The VLRV series LFP battery incorporates the highest safety performance lithium iron phosphate technology, available in two specifications: VLRV2560 and VLRV5120. Each battery module has a built-in full-featured & high-precision battery management system (BMS), enabling real-time monitoring of voltage, current and temperature. The batter module features a passive balance function, effectively enhancing battery performance.

Moreover, the VLRV2560 and VLRV5120 batteries feature a special structural design. The metal strips can be used not only as a handle, but also as a “floor lock” & “rear lock”. They can also act as connecting strips when multiple batteries are used in combination, greatly improving installation efficiency and reducing the need for special tools. This design expands the battery’s application scenarios. The battery also incorporates unique safety designs (including cell, structure, bracket, and aerosol automatic fire extinguishing device), that greatly enhance the safety performance of the battery.

Table 4-1: VLRV battery specification

Type	Voltage [V]	Capacity [Ah]	Energy [Wh]	Width [mm]	Depth [mm]	Height [mm]	Weight [kg]
VLRV1280A	12.8	100	1280	308	172	220	11.2
VLRV2560A	12.8	200	2560	460	220	213	24
VLRV5120A	12.8	400	5120	460	320	247	43

Type	Voltage [V]	Capacity [Ah]	Energy [Wh]	Width [mm]	Depth [mm]	Height [mm]	Weight [kg]
VLRV2560B	25.6	100	2560	460	220	213	24
VLRV5120B	25.6	200	5120	460	320	247	43.5

Type	Voltage [V]	Capacity [Ah]	Energy [Wh]	Width [mm]	Depth [mm]	Height [mm]	Weight [kg]
VLRV5120C	51.2	100	5120	460	320	247	44

4.2 Module Illustration and Front Panel Description

4.2.1 VLRV1280 Appearance & Dimension Schematic Diagram

Figure 4-1: VLRV1280 Series Appearance drawing

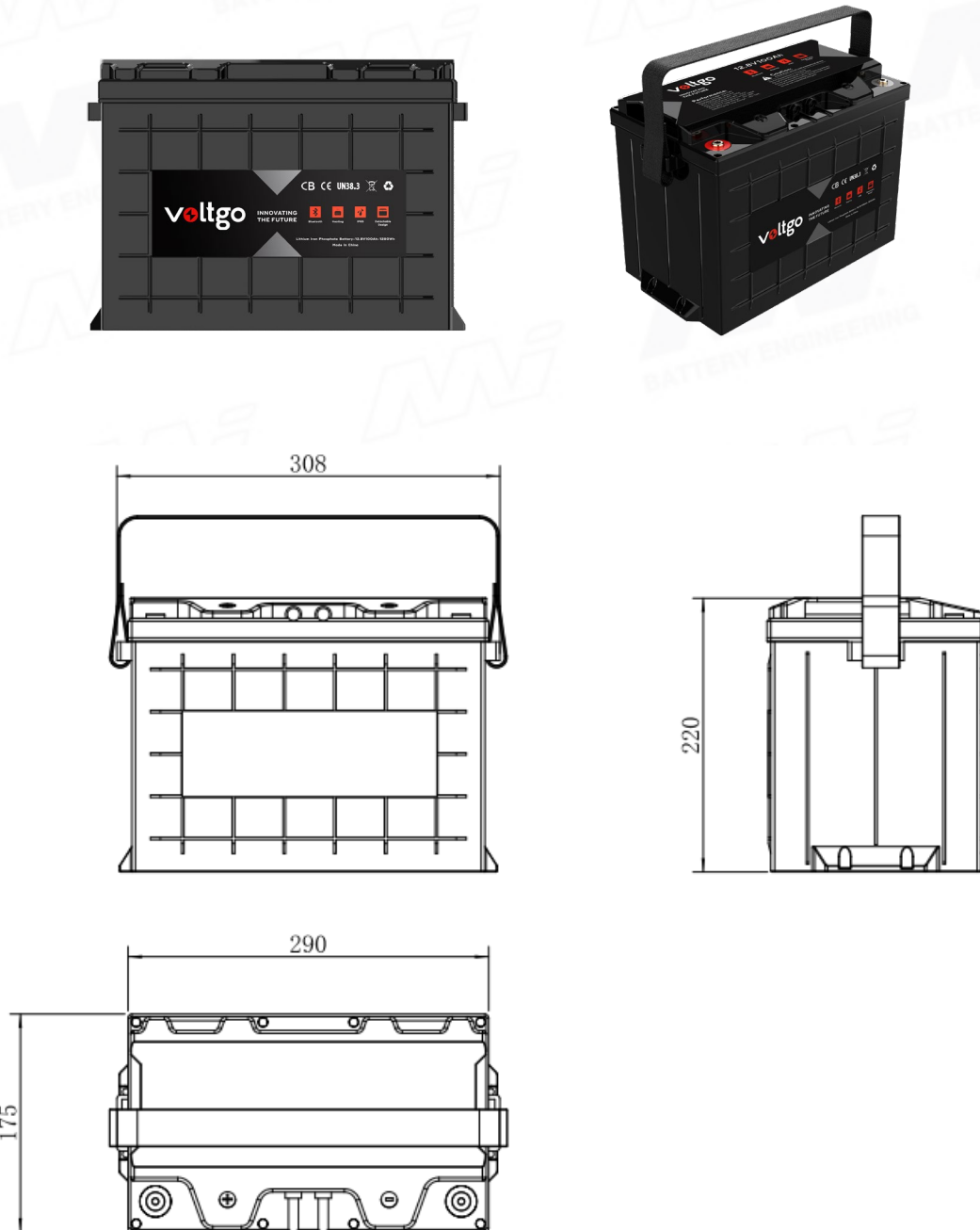

4.2.2 VLRV2560 Appearance & Dimension Schematic Diagram

Figure 4-2: VLRV2560 Series Appearance drawing

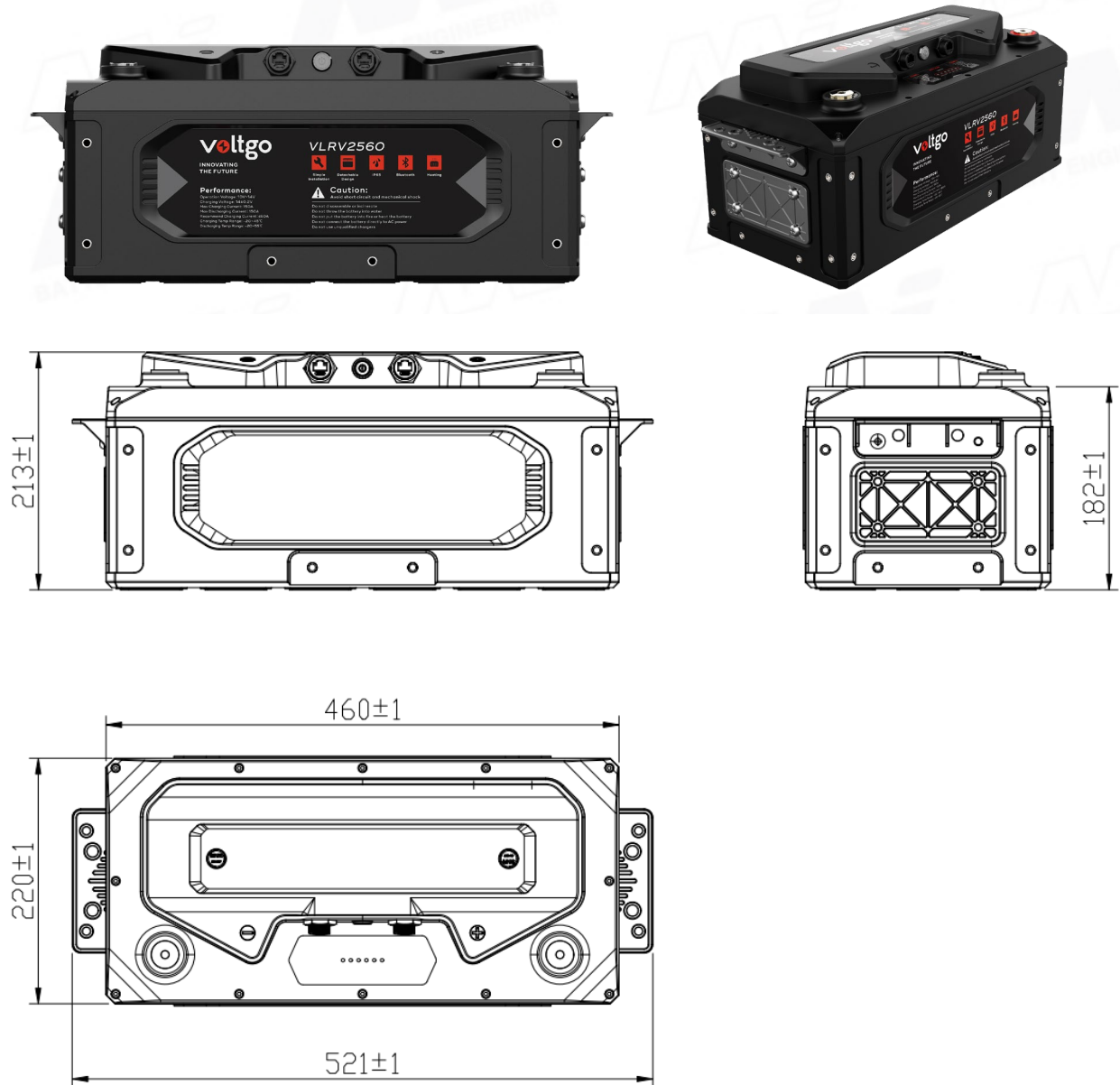

4.2.3 VLRV5120 Appearance & Dimension Schematic Diagram

Figure 4-3: VLRV5120 Series Appearance drawing

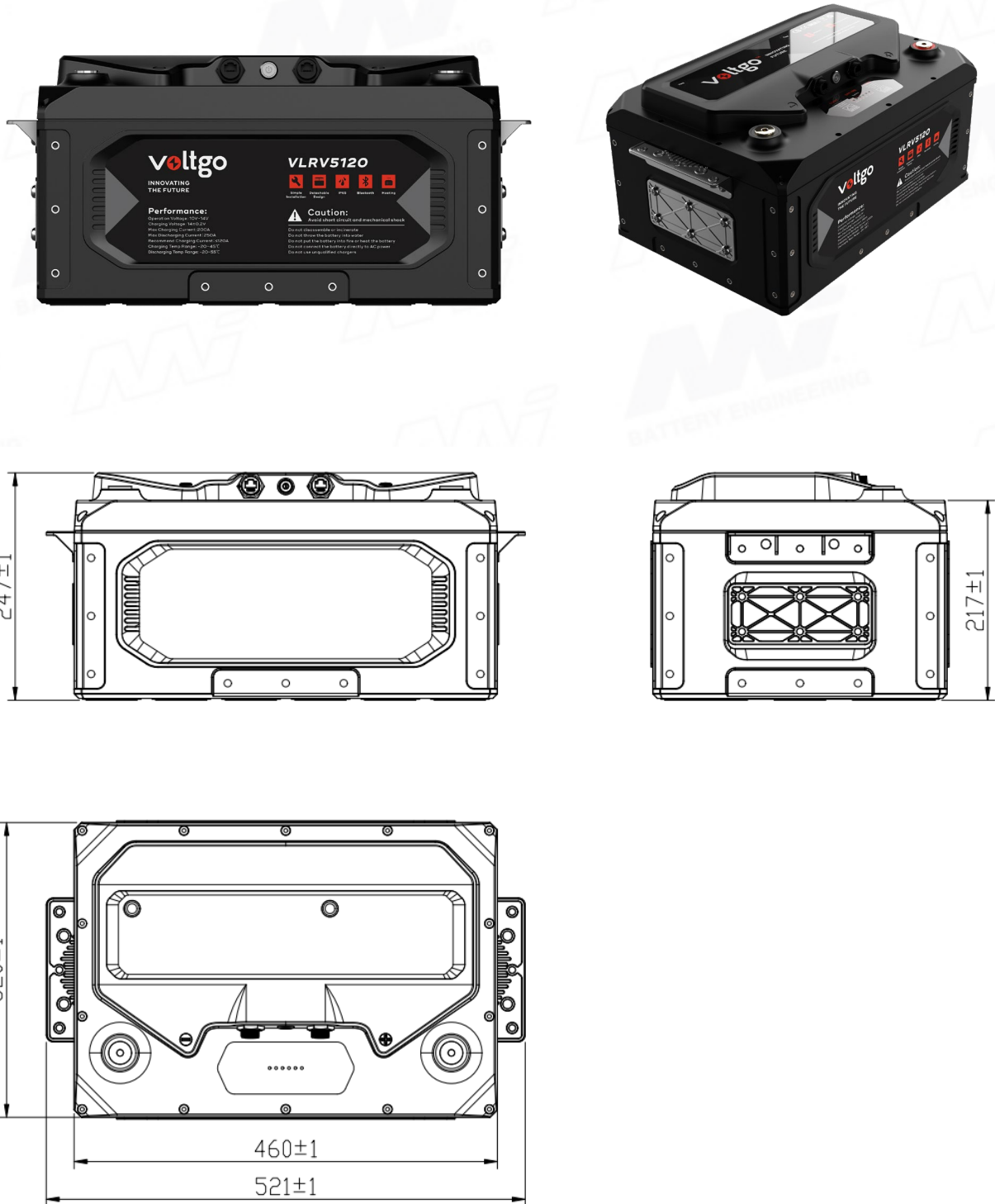

4.4 VLRV Series Battery Front Panel Diagram

Figure 4-4: VLRV Series Battery Front Panel

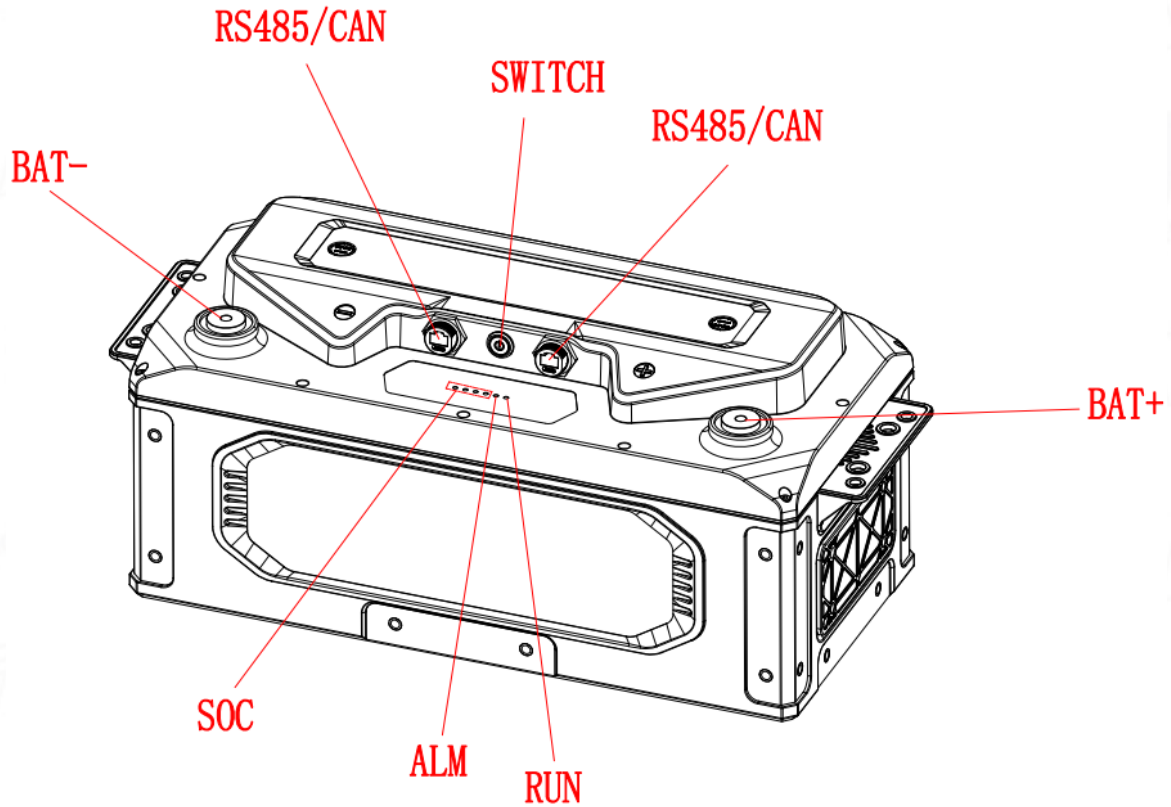

Table 4-1 VLRV series battery front panel interface description

No.	Item	Function Description	Remarks
1	BAT+	Positive terminal	M8 Screw
2	RS485/CAN	RS485/CAN Communication port	
3	Switch	Button Switch on/off the BMS	
4	BAT-	Negative terminal	M8 Screw
5	ALM	Alarming indicates LED	
6	RUN	Operating indicates LED	
7	SOC	The state of charge	4 nos green LED

4.5 LED Indicator status and definition

Table 4-2 LED indicator status and definition

Status	Normal/Alarm/ Protection	RUN	ALM	SOC Indicate LED	Notes
		●	●	SOC1~SOC4●	
Shutdown / Sleep		OFF	OFF	OFF	
Stand by	Normal	ON	OFF	Based on battery indicator (Each LED indicators 25%SOC)	Flash 1: OFF:1.0S/ON:1.0S
Charge	Normal	Flash 1	OFF		
	Alarm	Flash 1	OFF		
	End-off Voltage	ON	OFF		
	Over-Temp Protection	OFF	ON		
	Over-current transfer limit-current	OFF	ON		
Discharge	Normal	Flash 2	OFF	Based on battery indicator	Flash 2: OFF:0.5S/ON:0.5S
	Alarm	Flash 2	OFF		
	End-off Voltage	OFF	ON		
	Over-Temp/Over-current Protection	OFF	ON		

4.6 Communication Port Diagram and Description

Figure 4-5 Communication interface diagram

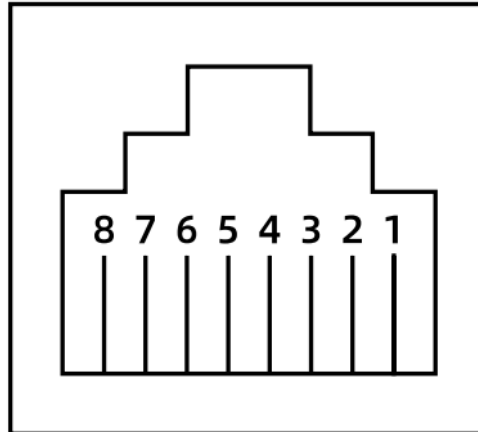

Table 4-3 Communication interface definition

Pin 1	RS485 B-(T/R-)	Pin-5	CAN-L
Pin-2	RS485 A+(T/R+)	PIN-6	/
Pin-3	/	PIN-7	RS485 A+(T/R+)
Pin-4	CAN-H	Pin-8	RS485 B-(T/R-)

5 Battery Installation

5.1 Handling, Transportation, Storage

5.1.1 Handling

Improper handling practices may cause short circuits or damage to the battery pack, resulting in battery leakage or fire.



Use forklifts or carts for handling.



Ensure that the dimensions of materials do not exceed the width and height of aisles and doors, and maintain a moderate speed.



Avoid situations where battery packs are inverted or stacked on top of each other during unloading.



Avoid touching the terminals during handling.



Avoid battery short-circuits during handling.

5.1.2 Transportation



To ensure safety, it is recommended to use a forklift or have multiple individuals handle the battery module due to its heavy weight.



Avoid dropping, throwing, and exposing the equipment to collisions or strong vibrations during transportation.

5.1.3 Storage



Short-term storage (within 3 months): If the battery is not used for a short period of time, the battery can be fully charged and stored in a dry, cool environment with non-corrosive gas. The recommended temperature range is 10~45°C, with a relative humidity of 60±30%. Store the battery away from strong electromagnetic fields and direct sunlight.



Long-term storage (over 3 months): If the battery is not used for more than 3 months, keep the battery SOC at 50%~70%. Store it in a dry, cool environment with non-corrosive gas. The recommended temperature range is 20~35°C, with a relative humidity of 50±15%. Store the battery away from strong electromagnetic fields and direct sunlight. Charge the battery once every 6 months to avoid irreversible capacity loss caused by long-term storage.

5.2 Battery Installation Requirement





5.2.1 Environment Requirement

Table 5-1:Environment requirement

Application scenarios	RV, solar lights, E-golf, E-boat, small energy storage
Operating Environment	All-weather
Discharge Temperature (°C)	-20~55
Storage Temperature (°C)	10~45
Humidity (%)	5~95% RH

5.2.2 Open-box Inspection

Table 5-2:Unpacking tools sheet

Item	Tools			
Tools	Slotted screwdriver 	Protective gloves 	Stripper 	Hammer 

The VLRV series products undergo thorough testing and inspection prior to leaving the factory. Upon receipt, please carefully inspect the products and sign for them after confirming their condition. If any damage is observed, please promptly contact the local distributor. When opening the box, please check the following:

- (1) Outer Packaging: Ensure that the outer packaging is intact and not damaged.
- (2) Quantity and Type: Verify that the quantity and type of goods received match the description provided in the bill of materials.
- (3) Internal Equipment: Inspect the internal components to ensure they are undamaged.

5.2.3 Precautions before Installation







-  Ensure that each battery module is fully charged when used in groups.
-  Avoid unnecessary movement or touching of the contact terminals after installation.
-  Avoid installing the battery near any sources of heat (such as a transformer).
-  Ensure that terminals exhibit a normal metallic luster before connecting. If the terminals appear dull or show obvious signs of rust, polish the terminals with sandpaper.
-  Avoid metal conductors from coming into contact with the positive and negative terminals of the battery.
-  Use appropriate tools and methods to avoid damage to the terminal. The recommended tightening torque is specified in the table.

Table 5-3: Torque parameter sheet

No.	Scope of application	Tightening torque value
1	M6	8.5N*m
2	M8	12.4N*m

5.3 Battery Installation

- ① Place the battery on a flat floor or shelf;
- ② Remove the "handle" on the casing. The metal part can be turned into a "ground lock" to fix the battery on the floor with an electric drill. If the metal part is placed on the side of the battery, it can serve as a "back lock" to attach the battery to the wall with an electric drill, as shown in 5-1;

Figure 5-1:RV Installation Drawing

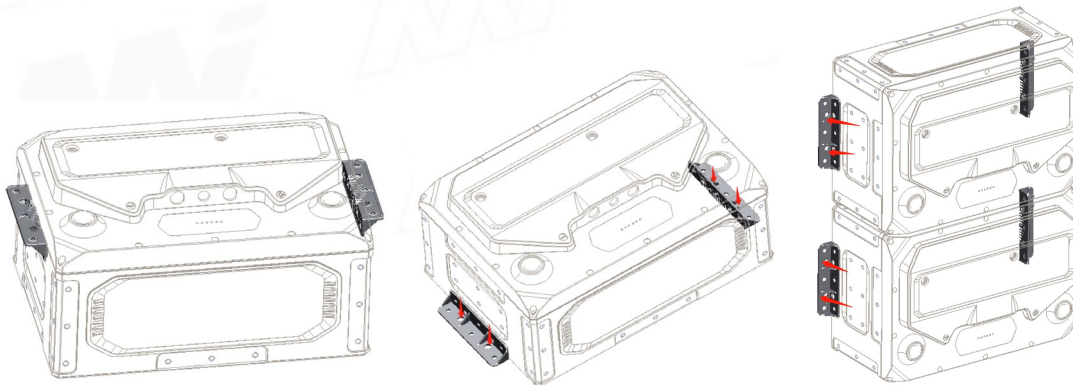

- ③ When multiple batteries are used in parallel, the rectangular metal strip can be used as a connecting plate. An electric wrench is used to connect the batteries together, as shown in 5-2;

Figure 5-2: RV Battery Installation Drawing

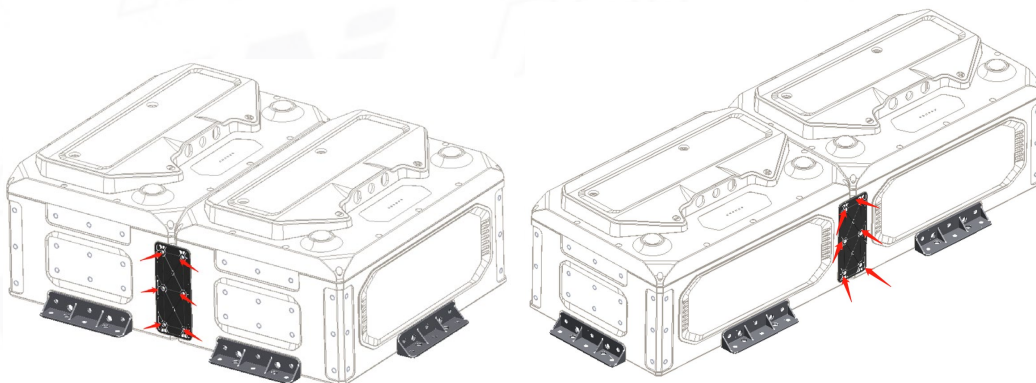

- ④ The VRLV series batteries support communication with Victron inverters via Cerbo GX and Victron Energy Ekrano GX by CAN to CAN-bus BMS type Cable(not included) . The battery cannot directly plug into the Victron inverter.

a) How to connect the battery with Victron Cerbo GX

Figure 5-3: Victron Cerbo GX

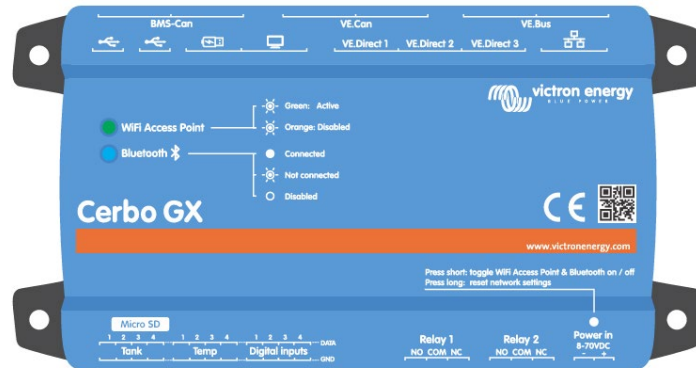

Connect the CAN port of our battery to the BMS-CAN port of Victron Cerbo GX by CAN to CAN-bus BMS type Cable.

Figure 5-4: Victron Cerbo GX BMS-CAN port and Voltgo Elite series battery CAN port

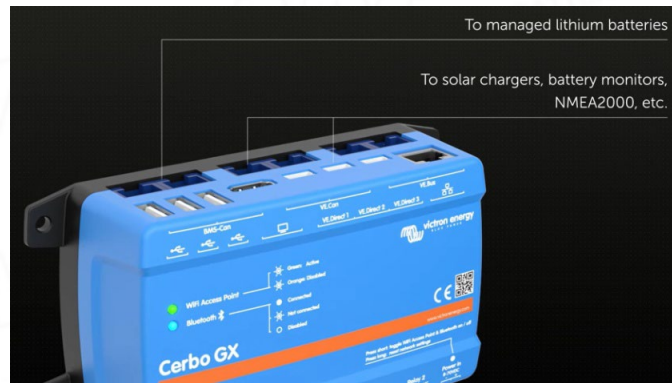

b) How to connect the battery with Victron Energy Ekrano GX

Figure 5-5: Rear of Victron Energy Ekrano GX



Connect the CAN port of our battery to the VE Con port of Victron Energy Ekrano GX by CAN to CAN-bus BMS type Cable.

Figure 5-6: Victron Energy Ekrano GX VE Con port and Voltgo Elite series battery CAN port

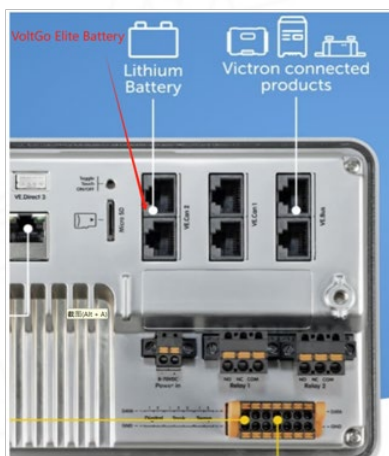

c) How to connect the batteries each other

Figure 5-7: Connecting the communication port between parallel voltgo batteries.

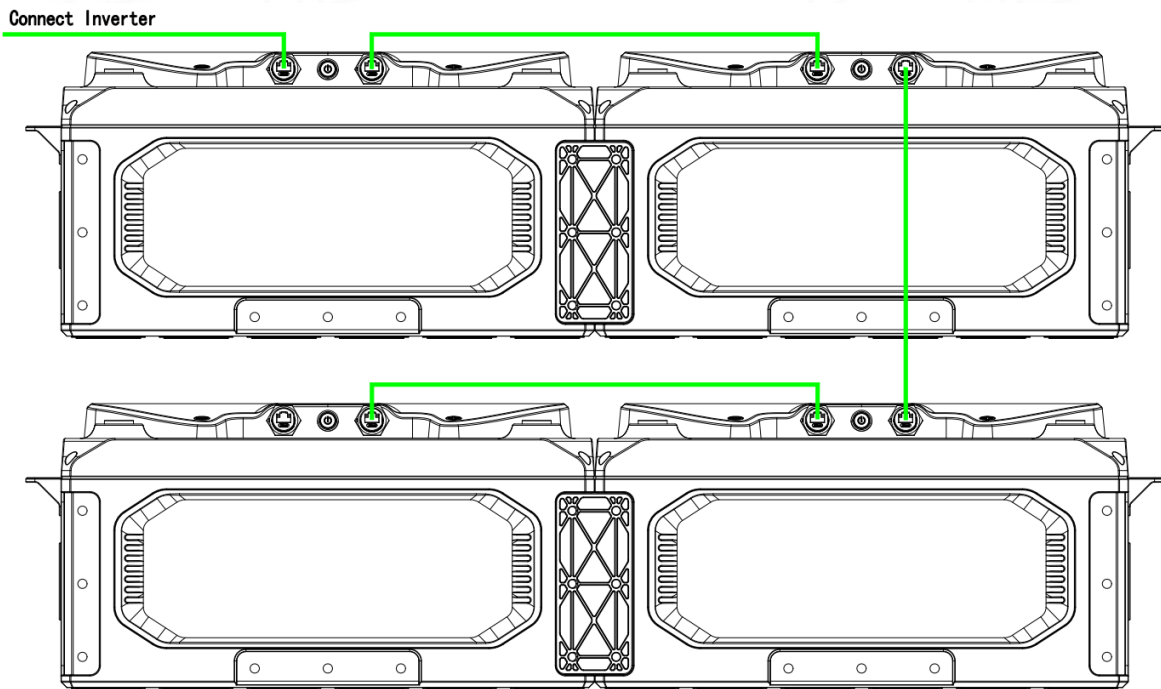

d) How to make CAN communication data cable?

If you want to make your own cable, please note that the pin port for our battery's CAN port has pin 4 as H and pin 5 as L.

You need to identify the pin port on your Victron device based on the specific equipment you have purchased.

⑤ Parallel connect the power cables, as shown in 5-8;

Figure 5-8: RV Battery Power Cable Connection Diagram

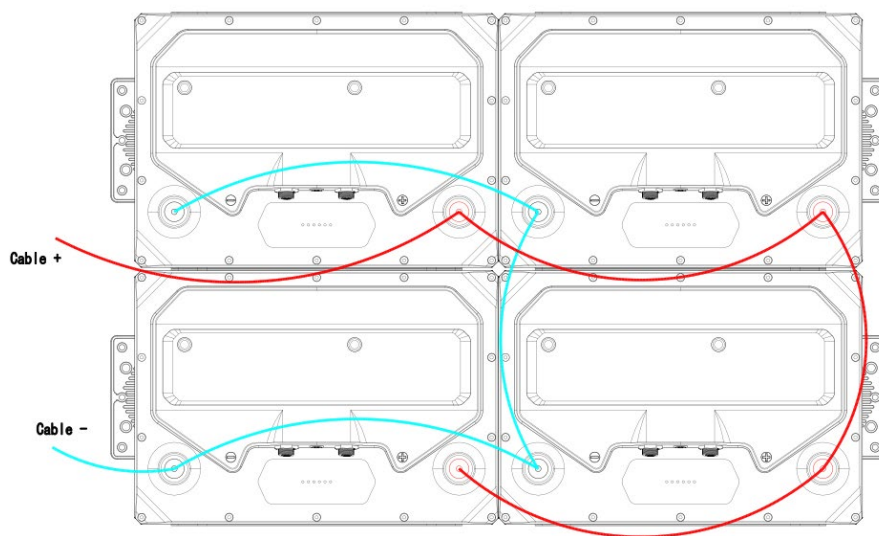

Tips:

- 1) If there is only one battery, connect the battery with address No.1 directly to the inverter. Connect the communication port of the battery to the corresponding inverter communication port.
- 2) If there are more than two battery modules in parallel, designate the battery with address No.1 as the master battery, which needs to be connected to the inverter for power output and communication. The other batteries (with different addresses) should connect to each other's communication ports. This allows all batteries and the inverter to establish communication.
- 3) Ensure that the slave batteries have different addresses from each other.
- 4) VLRV2560, VLRV5120 batteries do not support series connection. Please pay attention to the wiring method.
- 5) Only parallel batteries of exact same model and capacity. (Do not mix and match different voltages or capacities).
- 6) Must be technically proficient to install this battery.

6 Battery Use

To ensure proper communication between the VLRV battery and the inverter, the battery address and protocol settings need to be configured through Bluetooth. If used as a lead-acid battery, it can be directly connected in parallel without any further action.

6.1 Bluetooth Setting

- ① Download the Voltgo APP. Search for "Voltgo" on your phone's APP Store and download it, as shown in 6-1;

Figure 6-1: APP Store search



- ② Open the Voltgo APP and press OFF/ON switch of battery;
- ③ Connect the battery to the Voltgo APP via Bluetooth. Search for the battery and connect to it according to the Bluetooth label of battery. Then, click on "Connect". It will display battery information, as shown in 6-2;
- ④ The Bluetooth ID is located on the side of the battery. After selecting the battery ID in the app, click "Connect". The battery information will be displayed, shown in 6-2;

Figure 6-2: APP connection

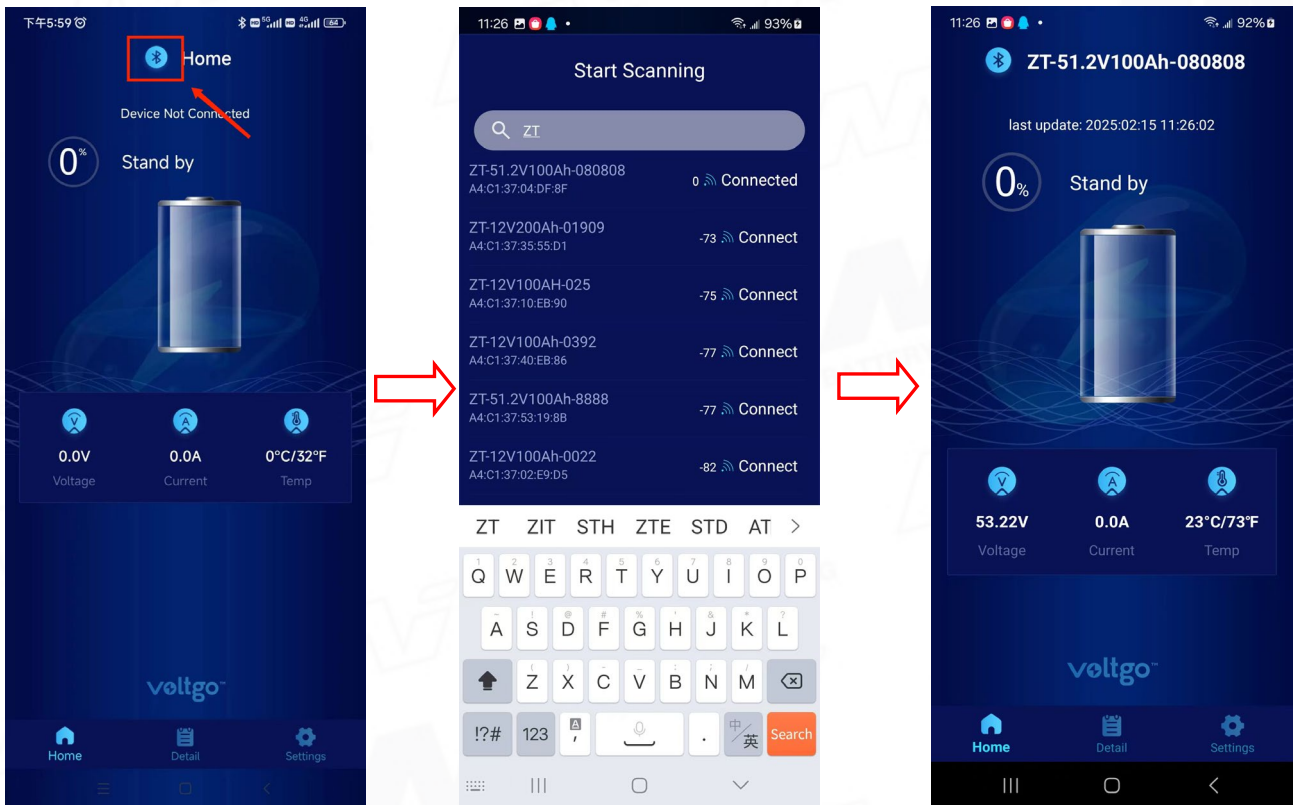

- ⑤ Select the ID Address. Enter the settings interface, click on "Module ID", and select the appropriate ID (defaults=1), as shown in 6-3;
- ⑥ Select the protocol. Select the corresponding protocol according to the connected inverter, as shown 6-3.

Figure 6-3:APP Setting

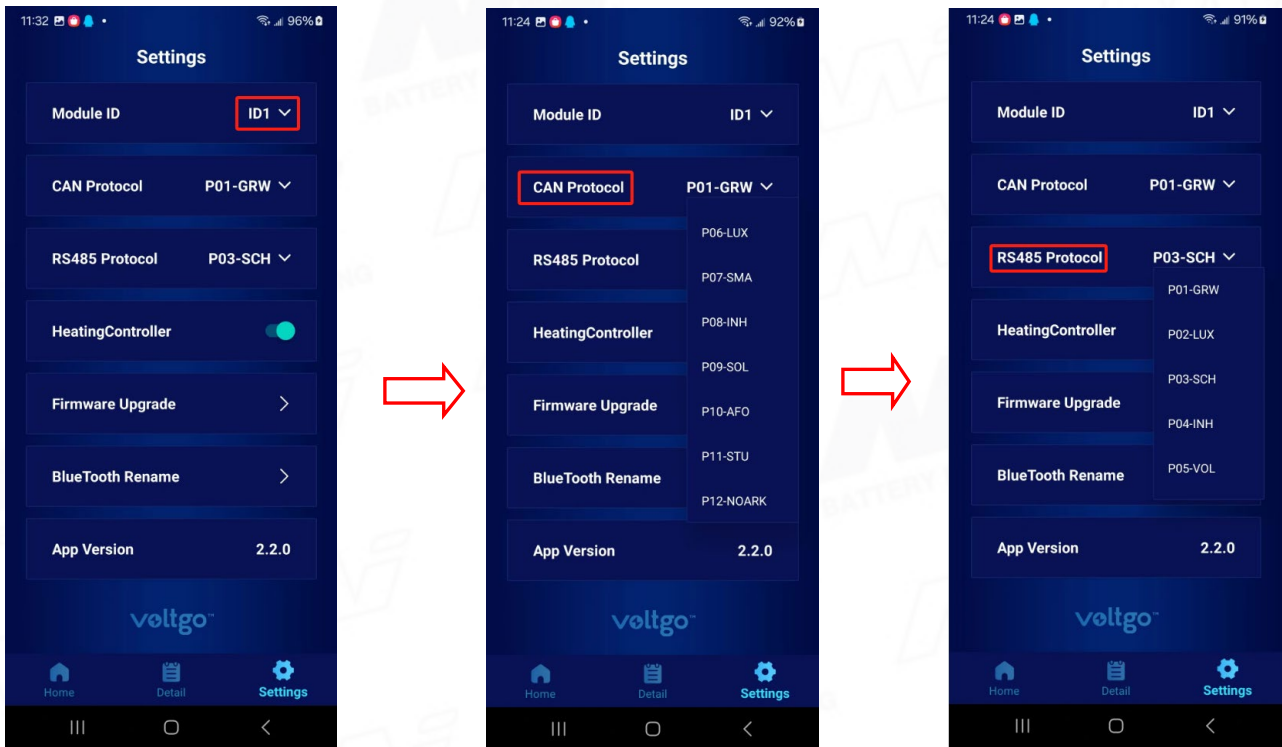

Tips: Support Inverter brand List

RS485		CAN			
01	Growatt	01	Growatt	09	Solis
02	Luxpower	02	Sol-Ark	10	Afore
03	Schneider	03	Deye	11	Studer
04	Inhenergy	04	Megarevo	12	NOARK
05	Voltronic	05	Victron		
/	/	06	Luxpower		
		07	SMA		
		08	Inhenergy		

Note: After changing any settings in the app, apply the changes by turning the battery off and then back on using the power switch.

6.2 Heating Settings

Heating settings are as shown in Figure 6-4:

- ① Click the heating to turn on and open the heating film heating function. When the low temperature condition is met, the battery starts to heat.
- ② Click the heating off, close the heating film heating function, when the low temperature condition is met, the battery prohibit heating.

Figure 6-4: Heating Setting

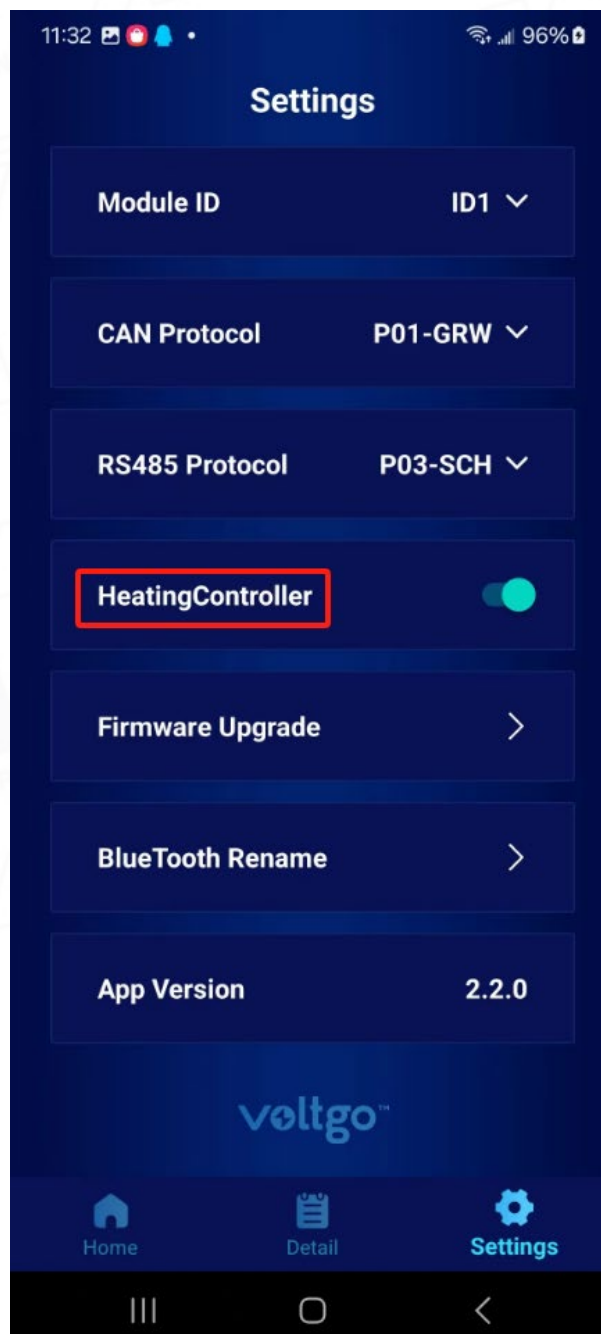

6.3 Firmware Upgrade

6.3.1 Comm pcb Upgrade

- ① Click "Firmware Upgrade" firmware upgrade;
- ② Click "Comm PCB";
- ③ Click "BROWSE" to select the program;
- ④ Enter password: zt123;
- ⑤ Select the program "ZTHV-C" as the communication board program; (Note: Product model number)
- ⑥ Click "Done" ;
- ⑦ Click "UPGRADE" to start downloading;
- ⑧ The word "Upgrade Success" was downloaded successfully;
- ⑨ Return to the main page and click "Comm PCB" to display the current communication board version number.

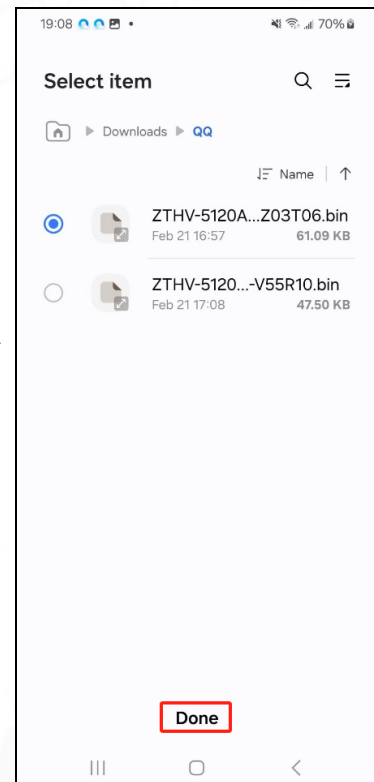
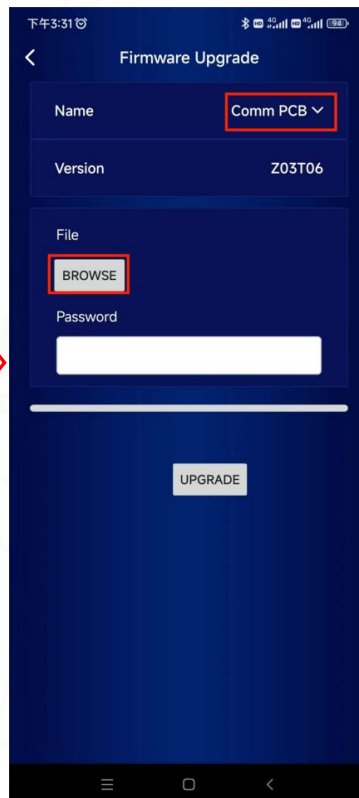
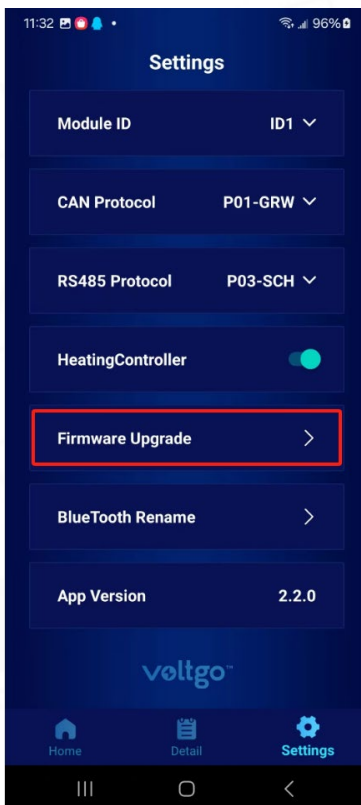

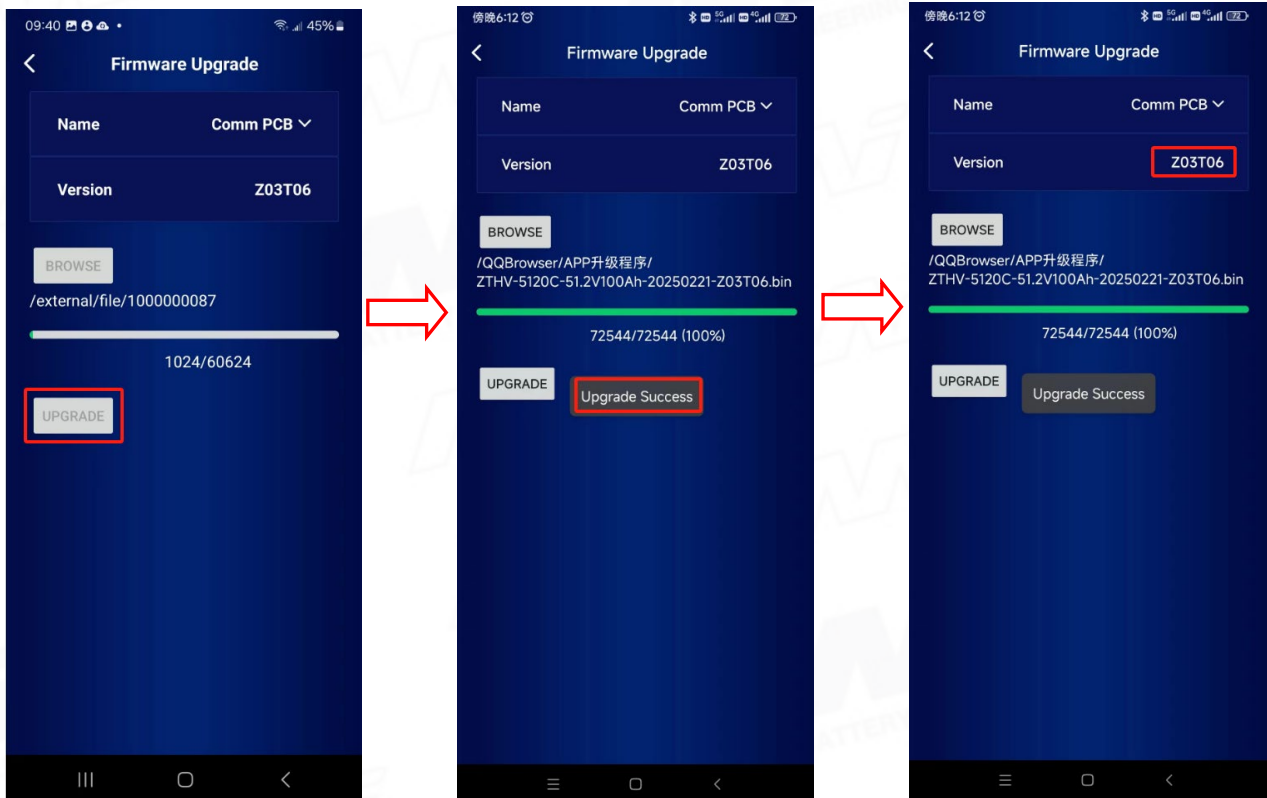

6.3.2 BMS Upgrade

- ① Click "Firmware Upgrade" firmware upgrade;
- ② Click "Comm PCB";
- ③ Click "BROWSE" to select the program;
- ④ Enter password: zt123;
- ⑤ Select the program "ZTHV-M" as the communication board program; (Note: Product model number)
- ⑥ Click "Done" ;
- ⑦ Click "UPGRADE" to start downloading;
- ⑧ Show 99%,Write Finish, Waiting for the device to restart;(The loading time is about 30s)
- ⑨ The word "Upgrade Success" was downloaded successfully;
- ⑩ Return to the main page and click "BMS" to display the current BMS version number.

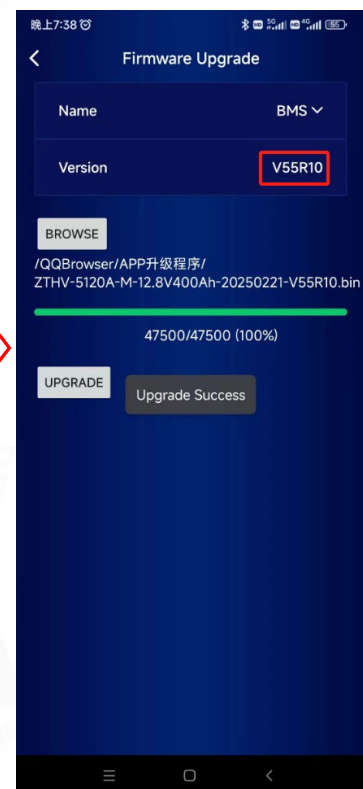
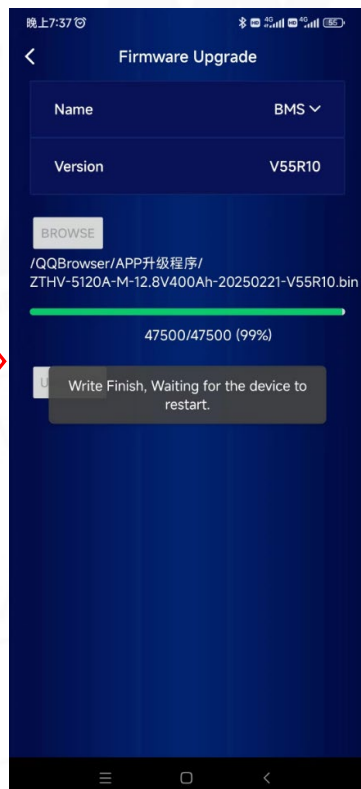
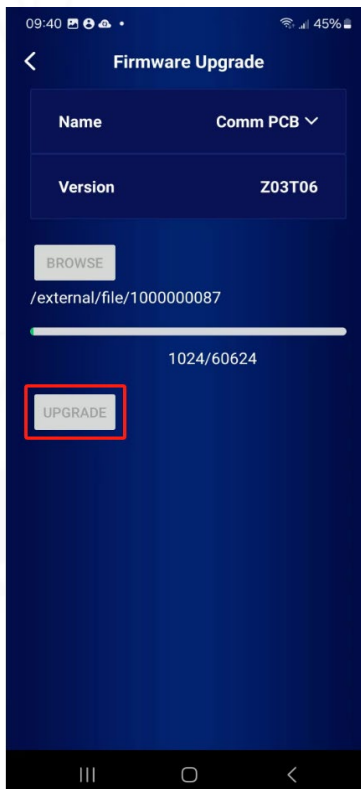
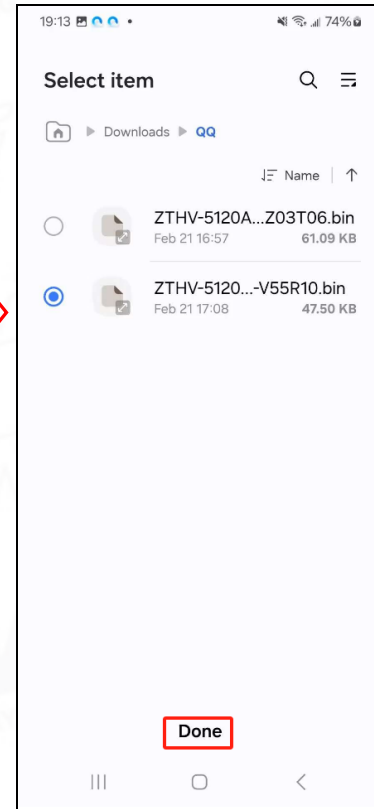
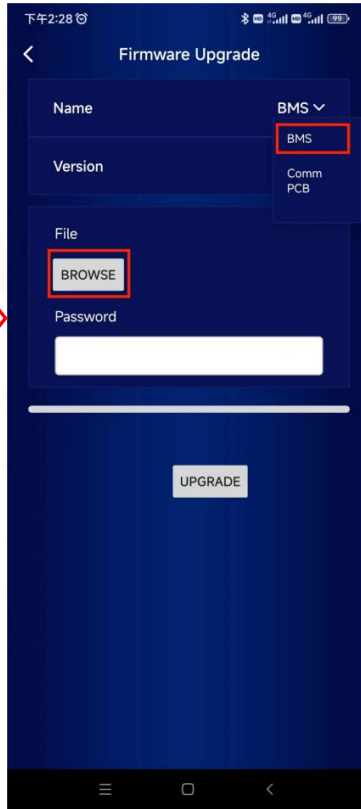
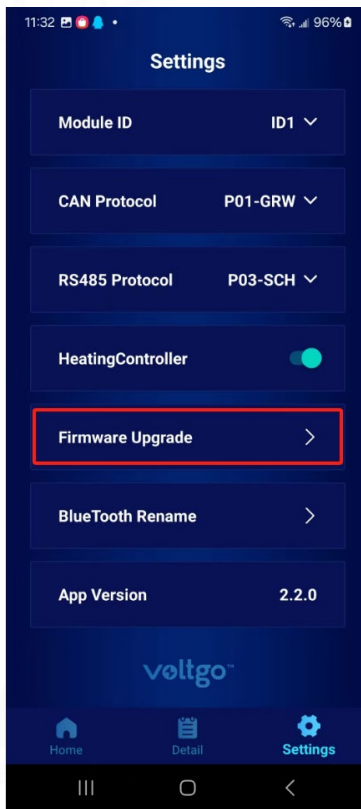

6.4 Bluetooth Rename

- ① Click "Bluetooth Rename" ;
- ② Click the name to modify, pay attention to the number of 22 digits;
- ③ Editing is completed, click "ok";
- ④ The word "Modify Successful" appears;
- ⑤ Restart the battery, and the modification is complete.

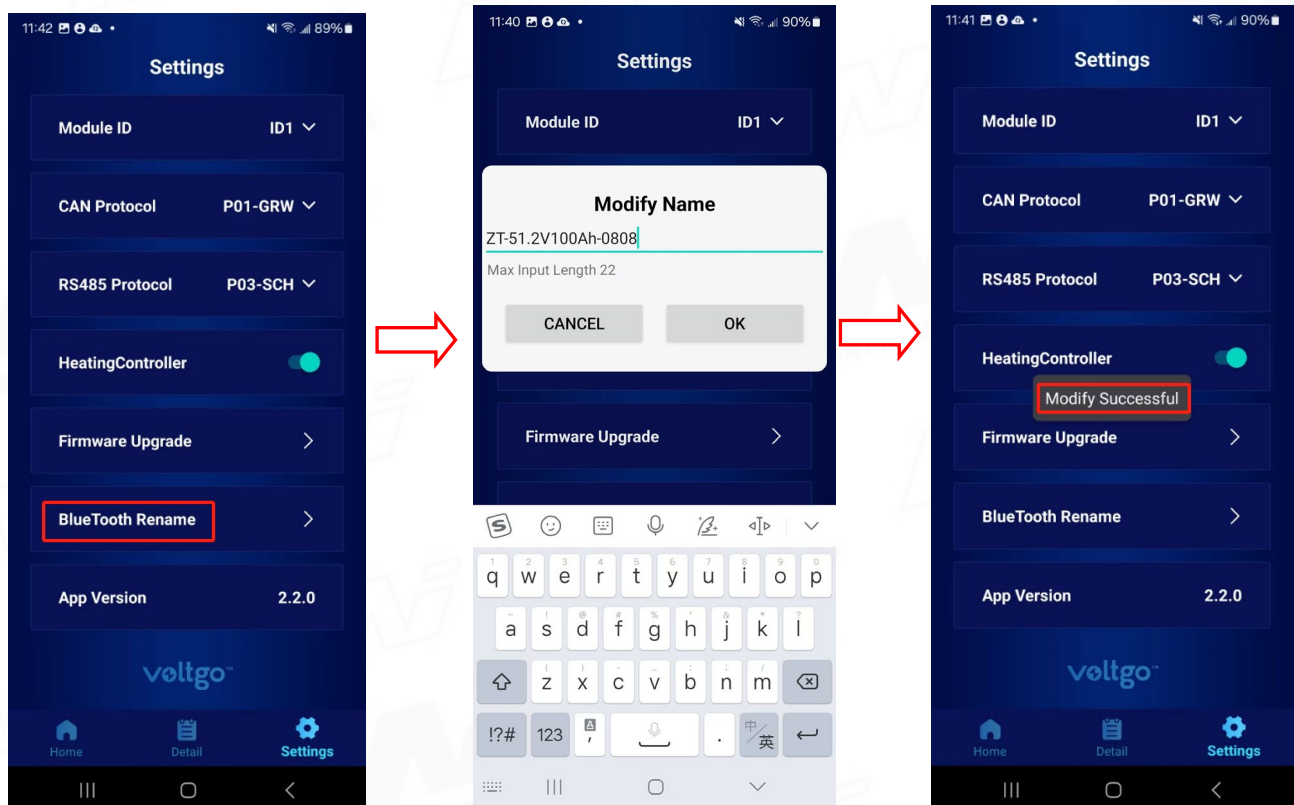

6.5 Battery status

Battery status is as shown in Figure 6-5:

Figure 6-5: APP Store search



Battery status corresponding Table 6-1:

Table 6-1: Fault status table

Status Information	Explain
CELL OVP	Single overpressure protection
CELL UVP	Single under-pressure protection
PACK OVP	Overpressure protection in the whole group
PACK UVP	The whole group is under pressure protection
CHG OTP	Charging high temperature protection
CHG UTP	CHG UTP Charging low temperature protection
DSG OTP	Discharge high temperature protection
DSG UTP	Discharge low temperature protection
CHG OCP	Charging over-current protection
DSG OCP	Discharge overcurrent protection
SHORT Circuit	short-circuit protection
FULL CHARGE	The battery full charged
FULL DISCHARGE	The battery is full discharged

6.6 Supplementary Power

- ① During transportation and storage, the battery may experience some power loss. It is recommended to fully charge the battery before use.
- ② If the battery will not be used for a certain period of time, it should be regularly recharged.
- ③ Please refer to the table below for the recommended time intervals and methods of recharging.

Table 6-2: Battery storage temperature and time interval for recharging

Storage Temp	Recharging interval	Charging method	Remarks
≤20°C	Once/9M	14V50A CC/CV Charging to 14V, cut-off current:5A	Only for 12.8V module
20°C~30°C	Once/6M	14V50A CC/CV Charging to 14V, cut-off current:5A	
30°C~40°C	Once/3M	14V50A CC/CV Charging to 14V, cut-off current:5A	
≤20°C	Once/9M	28V50A CC/CV Charging to 28V, cut-off current:5A	Only for 25.6V module
20°C~30°C	Once/6M	28V50A CC/CV Charging to 28V, cut-off current:5A	
30°C~40°C	Once/3M	28V50A CC/CV Charging to 28V, cut-off current:5A	
≤20°C	Once/9M	56V30A CC/CV Charging to 56V, cut-off current:5A	Only for 51.2V module
20°C~30°C	Once/6M	56V30A CC/CV Charging to 56V, cut-off current:5A	
30°C~40°C	Once/3M	56V30A CC/CV Charging to 56V, cut-off current:5A	

6.7 Battery Discharge and End-of-life Assessment

6.7.1 Battery Discharge

The BMS will automatically cut off the battery when it reaches the lower-limit voltage, without requiring human intervention. To avoid over-discharging the battery after the battery discharge termination, do not continue to apply a load to the battery.

6.7.2 Capacity Test

According to the battery specifications, the standard capacity calibration method involves charging and discharging the battery for three cycles. The final capacity observed after these cycles represents the actual capacity of the battery. If the testing temperature and conditions vary, the capacity value may fluctuate to a certain extent.

7 Maintenance

7.1 Common Faults (Phenomenon) and Solutions

Common faults and solutions are shown in Table 7-1.





Table 7-1 Common faults (phenomenon) and solutions

NO.	Fault phenomenon	Analysis	Solution
1	Communication failure with inverter	Communication port connect error or battery ID setting error	Refer 6. Battery use
2	No DC output	Not press switch or low voltage	Press switch or charge the battery
3	Power supply time is too short	Battery capacity lack or not full power	Maintenance or replacement
4	Battery can't be charged fully	Power system DC output voltage falls below the minimum charge voltage	Regulating DC output voltage of power supply to battery suitable charging voltage
5	ALM LED always lights	Power line connection short circuit	Disconnect the power cable and check all cables
6	The battery output voltage is unstable	Battery management system does not operate normally	Press the switch to restart the battery
7	The charge and discharge capacity is insufficient	Unbalance voltage with cell	Examine/balance the cell
8	Unable to charge and discharge	BMS or cell/temperature sensor damaged	Maintenance or replacement
9	Different SOC value of batteries in parallel	Normal phenomenon	No operation

7.2 Daily Maintenance

Routine maintenance items are shown in Table 7-2 below.

Table 7-2 Routine maintenance items

Item	Maintenance Method	Maintenance intervals
<p>Power Cables</p>   	<ol style="list-style-type: none"> 1. Inspect the power cable for any signs of mechanical damage and ensure that the terminal insulation sleeves are intact without falling off. If any damage is found, please turn off the machine and perform maintenance or replace the cable. 2. Check for any looseness in the power cable. If there is any signs of looseness, please use a standard torque wrench to tighten it. 3. Examine the system for loose screws or discoloration of the copper bus bar. If the screws are found loose, please tighten them with a standard torque wrench. If the copper bus bar is discolored, please contact the manufacturer for after-sales replacement. 	<p>Once every 6 months</p>
<p>Communication Cables</p> 	<ol style="list-style-type: none"> 1. Verify that the terminals of the parallel communication cable are securely tightened. If any terminal is loose, re-tighten it. 2. Check the communication cable for any obvious discoloration. If discoloration is present, please shut down the machine to replace the communication cable. 	<p>Once a year</p>
<p>Cabinet Cleanliness</p>	<p>Check the cleanliness of the front door, back door and battery module inside the cabinet. If it is dusty, please clean up in time.</p>	<p>Once 6-12 months</p>
<p>System Running Status</p> 	<ol style="list-style-type: none"> 1. Check if all parameters (system voltage, current, temperature, etc.) are normal when the system is running. 2. Check if the main core components of the system, including system switches and contactors, are functioning properly. 3. Inspect the system air inlet, outlet, and air ducts for any blockages or congestion. Clean them if any issues are detected. 	<p>Once every 6 months</p>
<p>Charge and Discharge Maintenance</p>	<p>Perform a light load and shallow charge/discharge test to assess the normality of the SOC and SOH status of the battery (using the upper computer software to read the parameters). It is recommended that the depth of discharge and charge/discharge power should not exceed 20% of the rated value.</p>	<p>Once every 6 months</p>

8 Cautions and Warranty

8.1 Cautions



Please read and comply with the following installation and usage conditions of the battery. Incorrect installation or use of the battery may cause personal injury or damage to the product.

- (1) DO NOT throw the battery into water. Store the battery in cool and dry environment.
- (2) DO NOT put the battery into fire or heat the battery, as it may cause explosion or other hazardous incidents.
- (3) During battery charging, please choose specialized charging equipment and follow correct procedures. Do not use unqualified chargers.
- (4) DO NOT reverse positive and negative terminals. Do not connect the battery directly to AC power. Avoid battery short circuits.
- (5) DO NOT using batteries from different manufacturers or different types together, and do not mix old and new batteries.
- (6) DO NOT use the battery when it is hot, bulging, deformed or leaking.
- (7) DO NOT puncture the battery with nails or other sharp objects. Do not throw, stamp on, impact or hit the battery.
- (8) DO NOT open or try to repair the battery when it is defective. Warranty becomes invalid if the battery is repaired or disassembled.
- (9) Batteries are half charged before shipment. Do not use the battery if it feels hot, bulges, emits an abnormal smell, or exhibits any other abnormalities. Report it to the after-sale department immediately.
- (10) If a long-time storage is needed, please charge and discharge the battery every three months to ensure the optimal performance. The recommended state of charge for storage is between 50% and 60%.
- (11) Please use the battery within the temperature range specified in the manual.
- (12) The state of charge of batteries is 50% before shipment. Please charge the battery before using.

8.2 Description of Warranty

We assure you that within the specified warranty period, our company will provide free repair and replacement services for any product damage or functional failure resulting from non-human or intentional causes. To avail of these services, customers are required to provide a valid purchase invoice or relevant product warranty information. In the absence of valid proof, our company reserves the right to decline providing related services.